

J. BECKER.
SEAMLESS TUBE ROLLING MACHINE.

(No Model.)

(Application filed May 12, 1900.)

21 Sheets—Sheet 1.

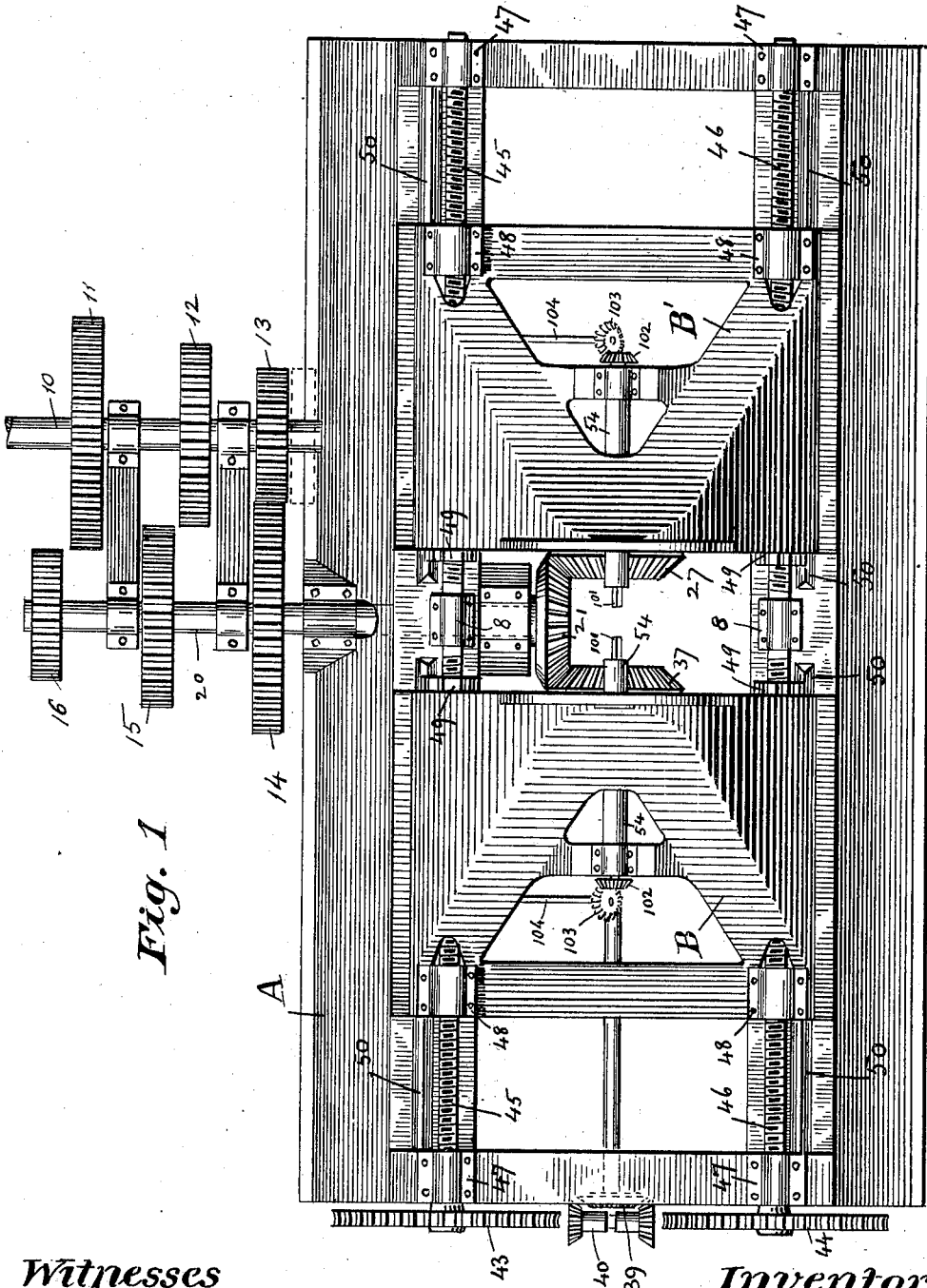

Fig. 1

Witnesses
W. M. Terrell
Frank S. Wolfe

Inventor
Joseph Becker

No. 653,335.

Patented July 10, 1900.

J. BECKER.

SEAMLESS TUBE ROLLING MACHINE.

(Application filed May 12, 1900.)

(No Model.)

21 Sheets—Sheet 2.

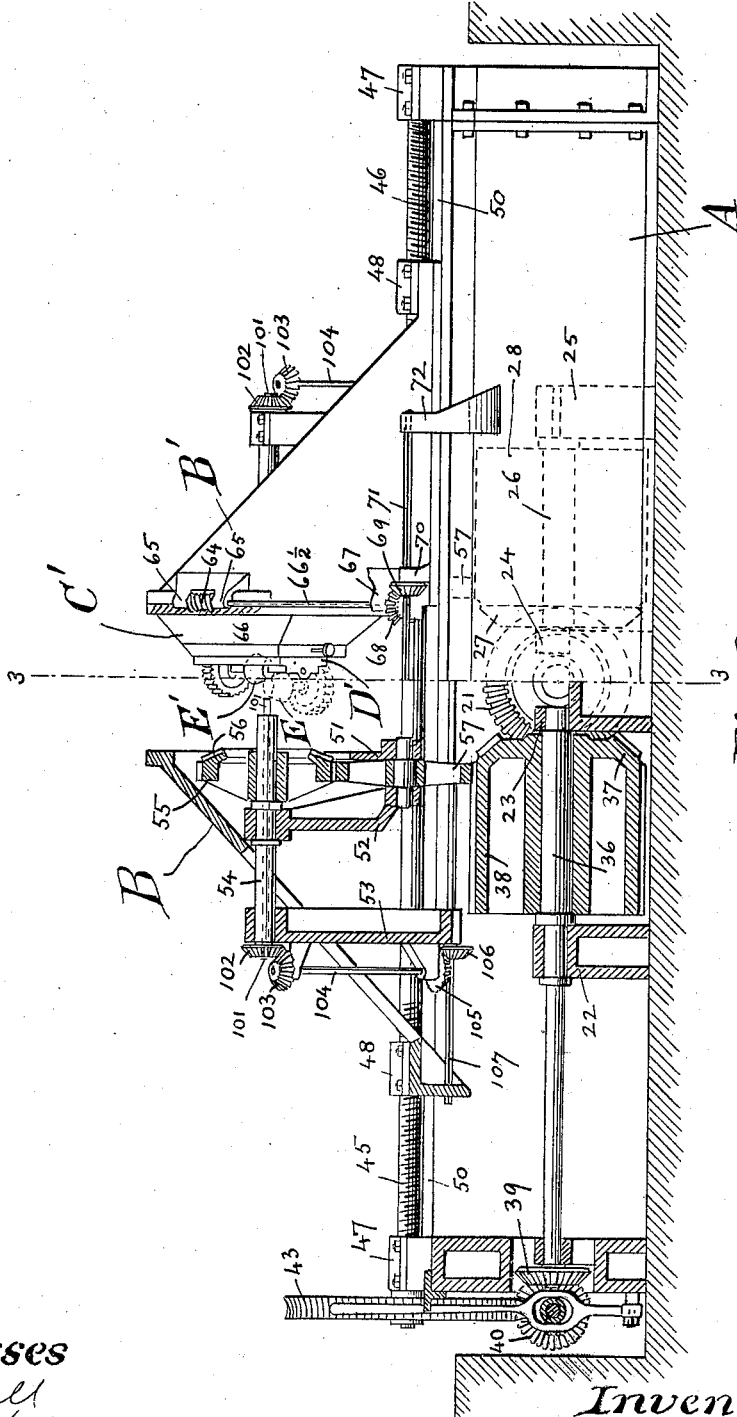

Fig. 2

Witnesses
W. M. Terrell
Frank. S. Hulfe

Inventor
Joseph Becker

J. BECKER.

SEAMLESS TUBE ROLLING MACHINE.

(Application filed May 12, 1900.)

(No Model.)

21 Sheets—Sheet 3.

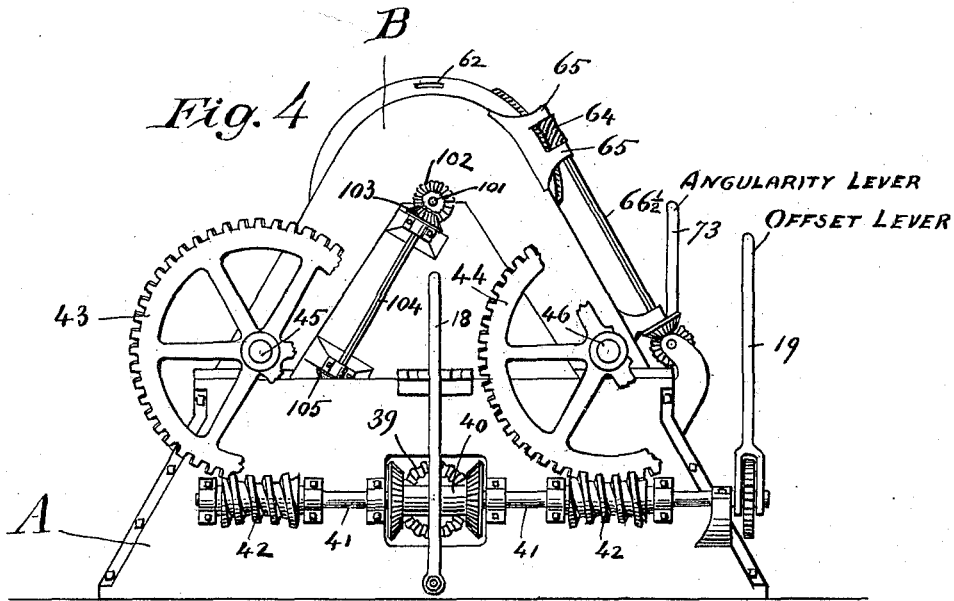
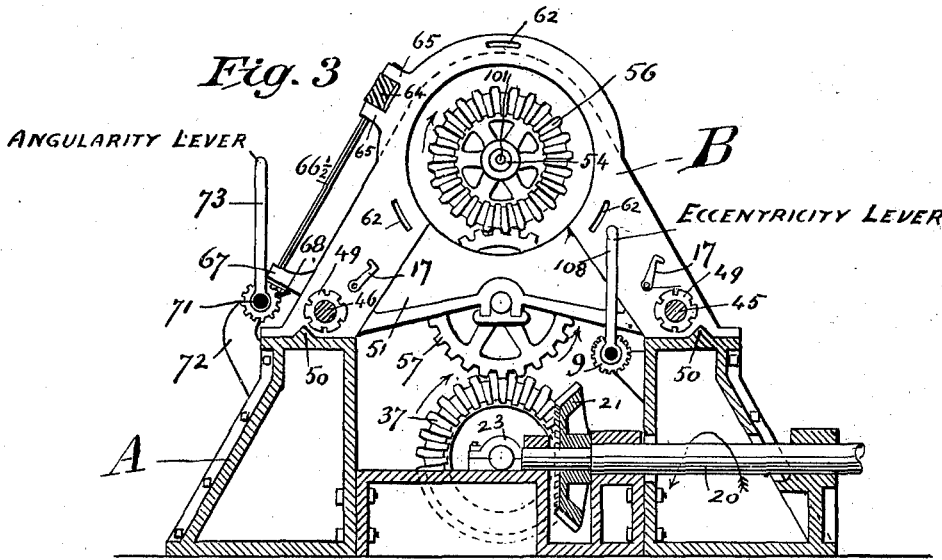

Witnesses
 W. M. Terrell
 Frank S. Wolfe

Inventor
 Joseph Becker

No. 653,335.

Patented July 10, 1900.

J. BECKER.

SEAMLESS TUBE ROLLING MACHINE.

(Application filed May 12, 1900.)

(No Model.)

21 Sheets—Sheet 4.

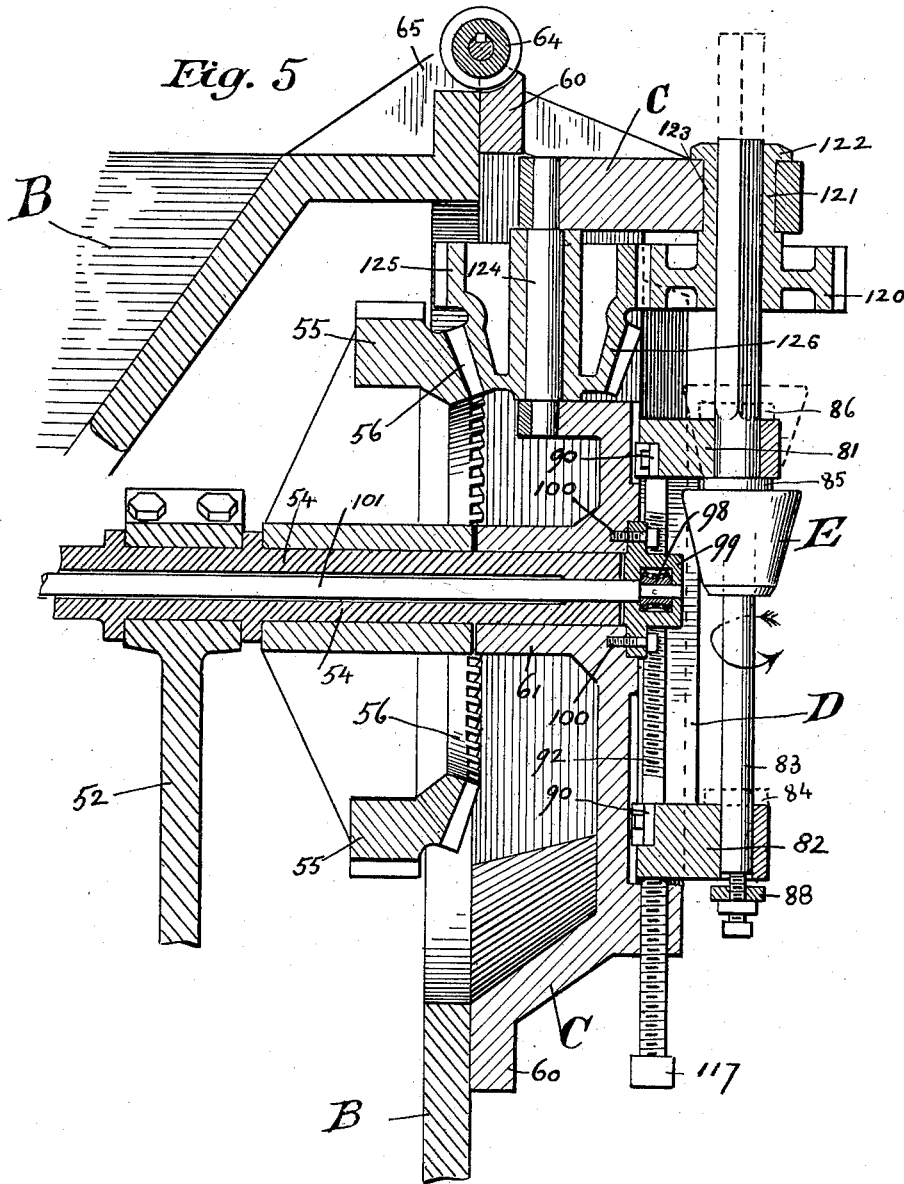

Witnesses
W. M. Terrell
Frank S. Wolfe

Inventor
Joseph Becker

J. BECKER.

SEAMLESS TUBE ROLLING MACHINE.

(Application filed May 12, 1900.)

(No Model.)

21 Sheets—Sheet 5.

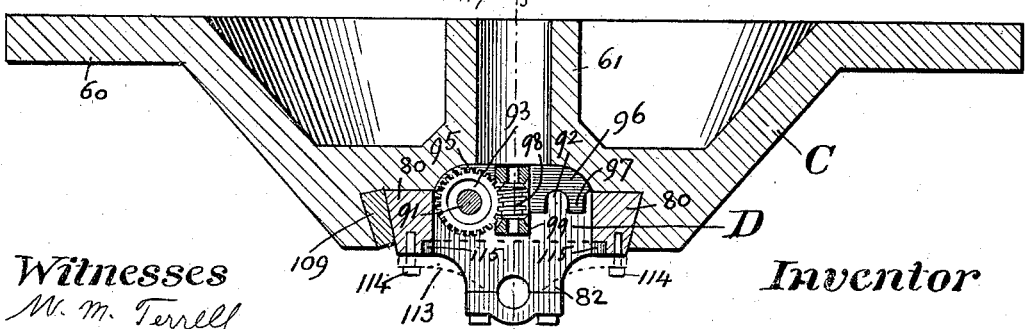
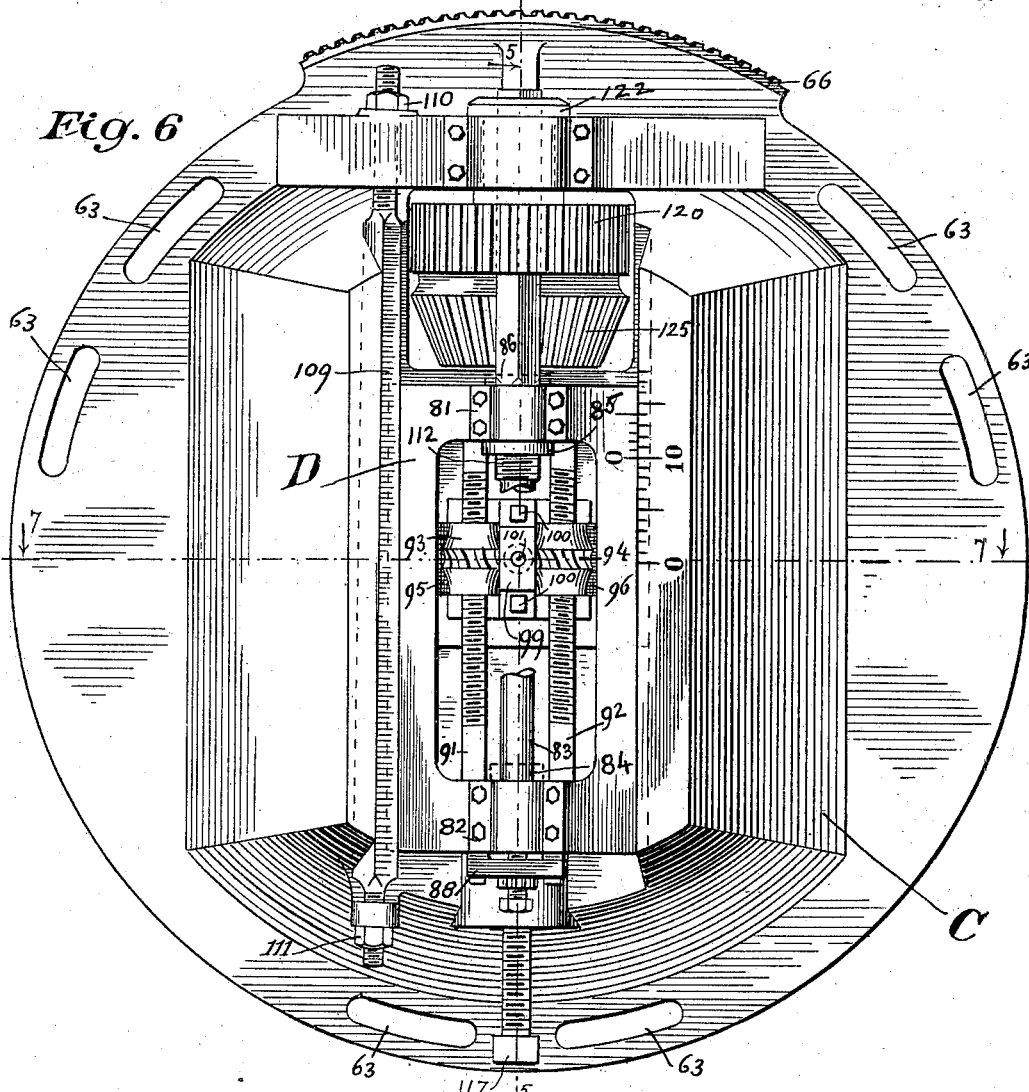

Fig. 6

Fig. 7

Witnesses
 W. M. Terrell
 Frank S. Hoffe

Inventor
 Joseph Becker

J. BECKER.

SEAMLESS TUBE ROLLING MACHINE.

(Application filed May 12, 1900.)

(No Model.)

21 Sheets—Sheet 6.

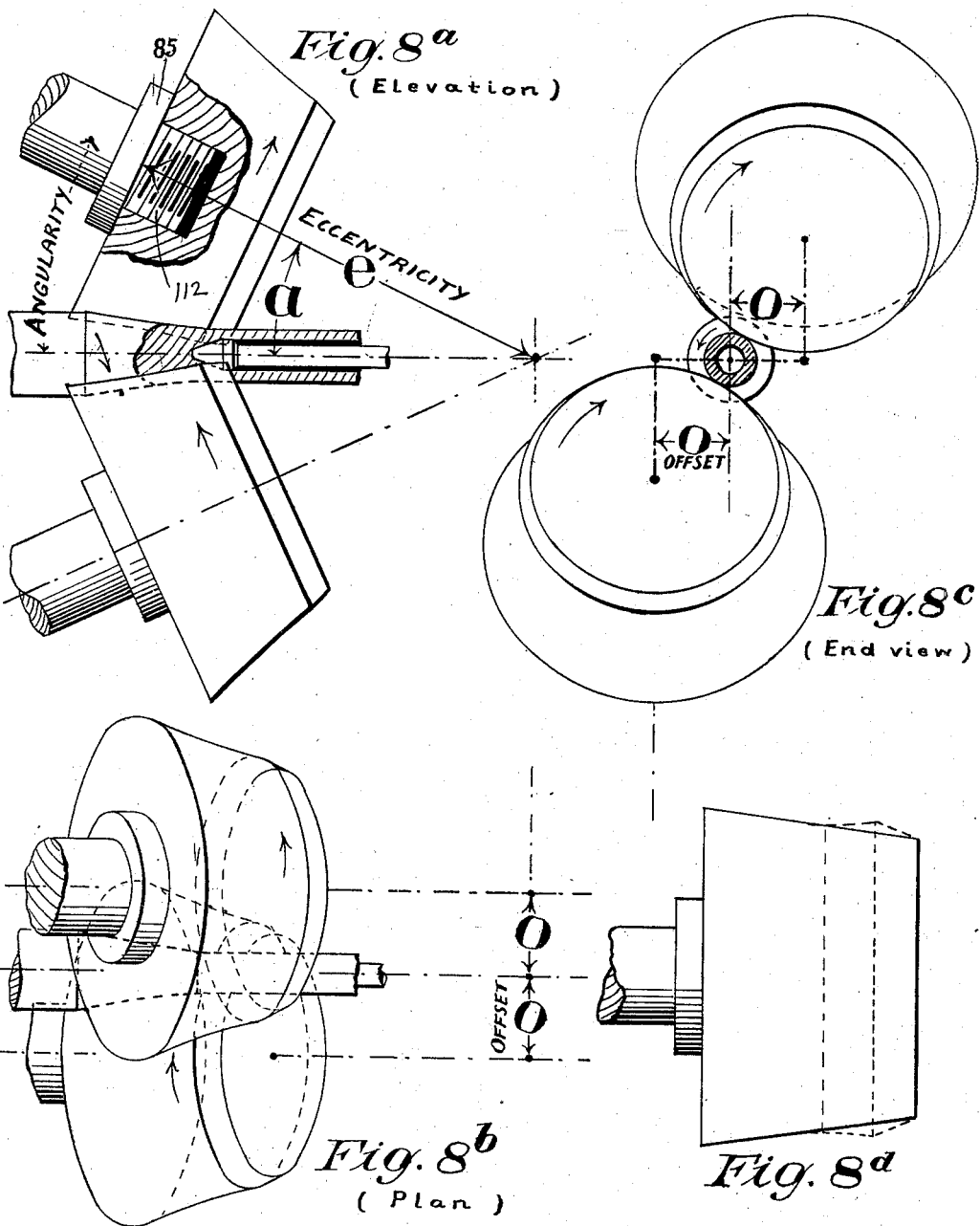

Witnesses
 W. M. Terrell
 Frank S. Wolfe

Inventor
 Joseph Becker

J. BECKER.
SEAMLESS TUBE ROLLING MACHINE.

(No Model.)

(Application filed May 12, 1900.)

21 Sheets—Sheet 7.

Fig. 9

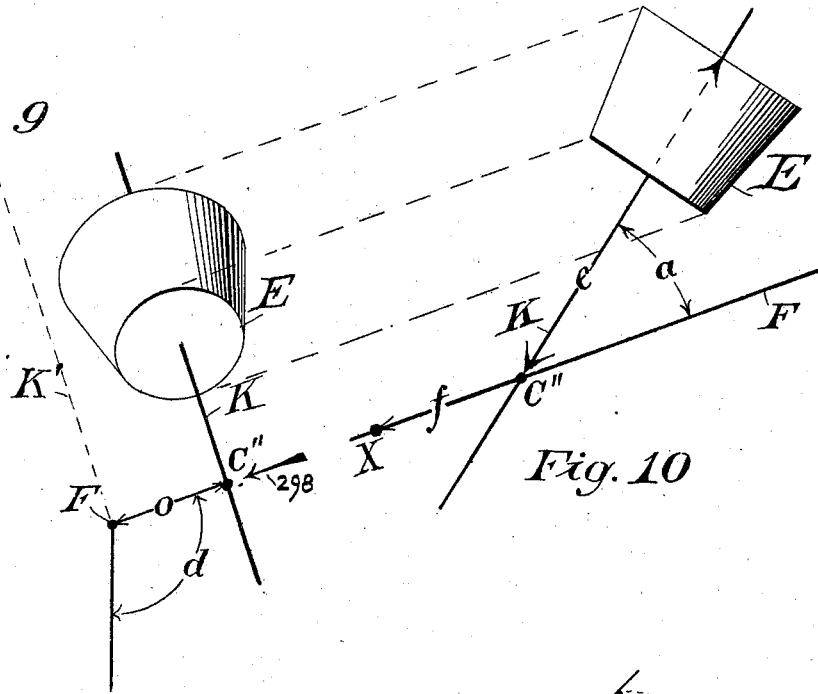
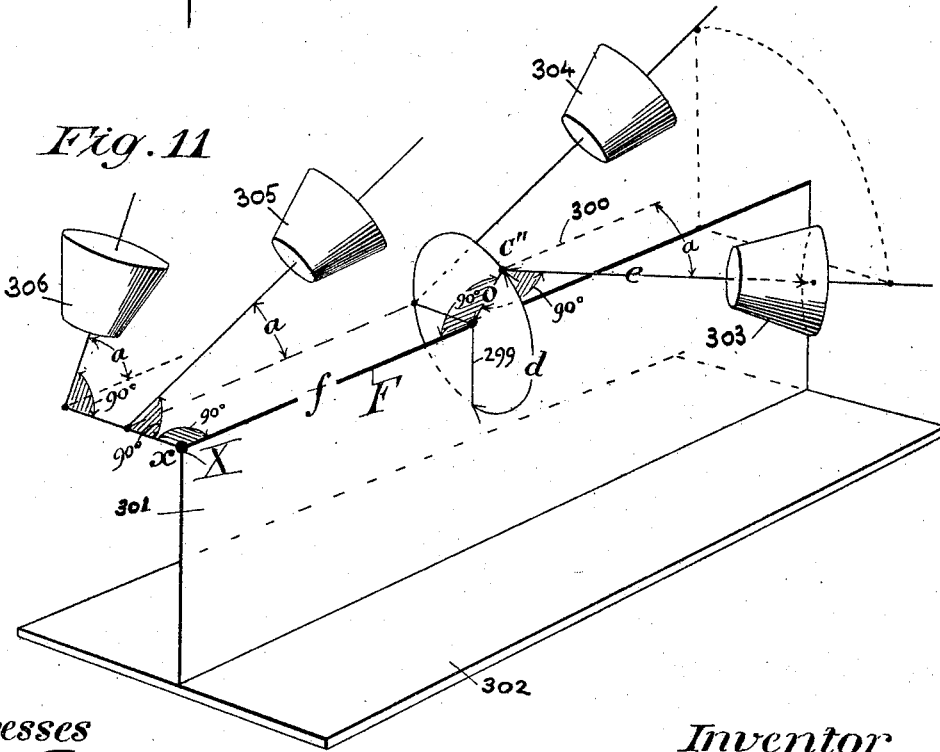

Fig. 10

Fig. 11



Witnesses
W. M. Terrell
Frank S. Wolfe

Inventor
Joseph Becker

J. BECKER.

SEAMLESS TUBE ROLLING MACHINE.

(Application filed May 12, 1900.)

(No. Model.)

21 Sheets—Sheet 8.

Fig. 12

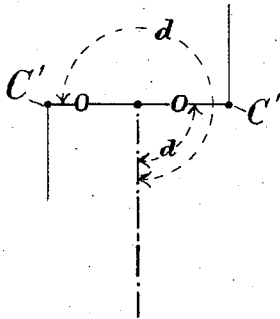

Fig. 13

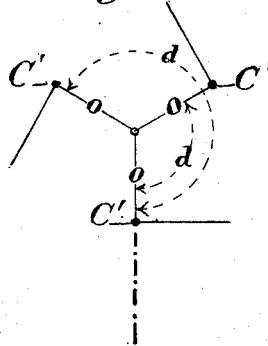

Fig. 14

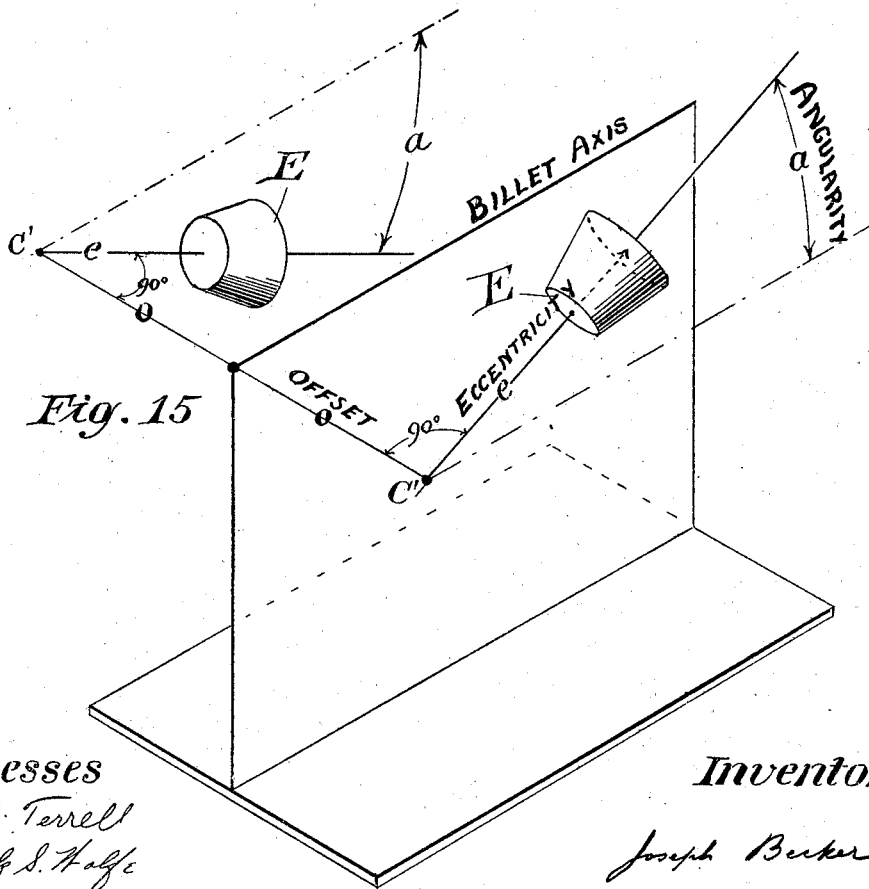
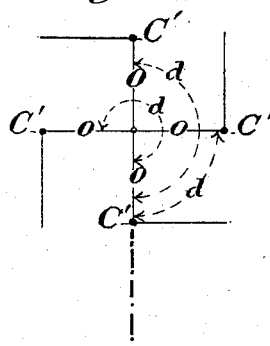

Fig. 15

Witnesses

W. M. Terrell
Frank S. Halle

Inventor

Joseph Becker

J. BECKER.
SEAMLESS TUBE ROLLING MACHINE.

(Application filed May 12, 1900.)

(No Model.)

21 Sheets—Sheet 9.

Fig. 16

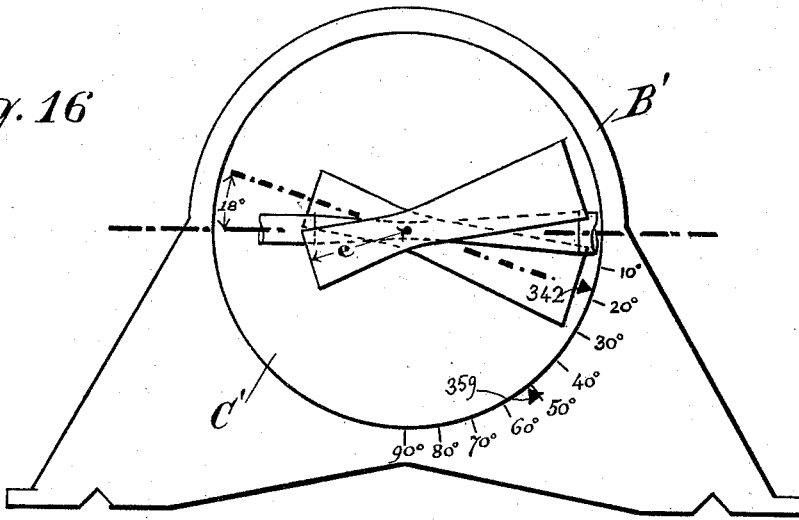

Fig. 17

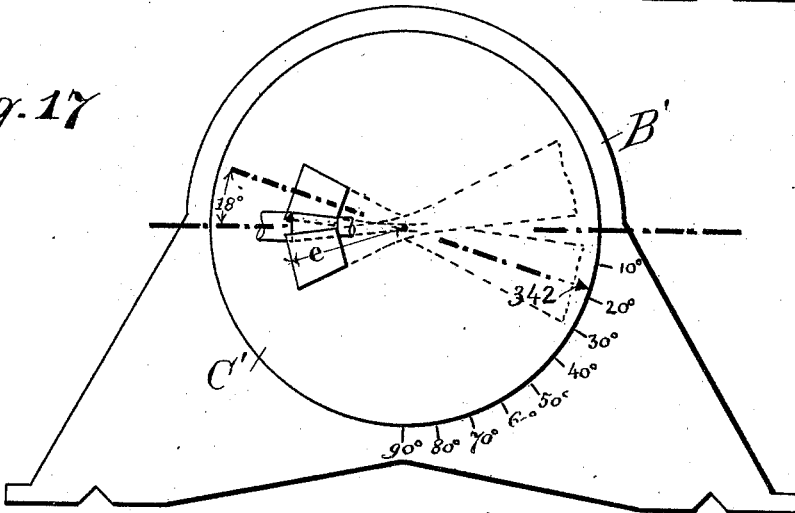
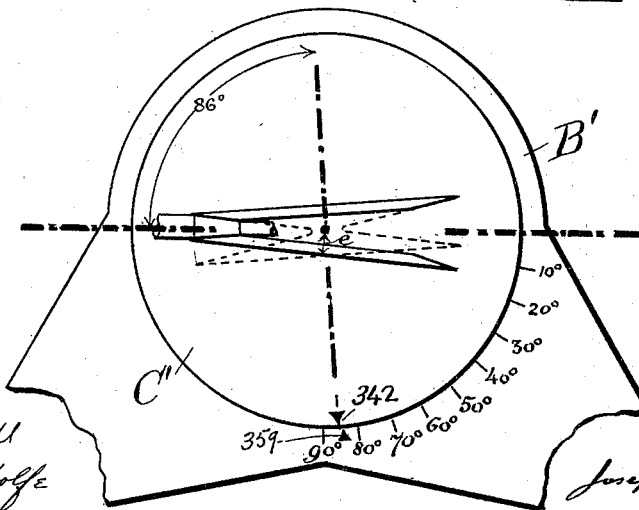

Fig. 18



Witnesses

W. M. Terrell

Frank S. Holze

Inventor

Joseph Becker

J. BECKER.
SEAMLESS TUBE ROLLING MACHINE.

(Application filed May 12, 1900.)

(No Model.)

21 Sheets—Sheet 10.

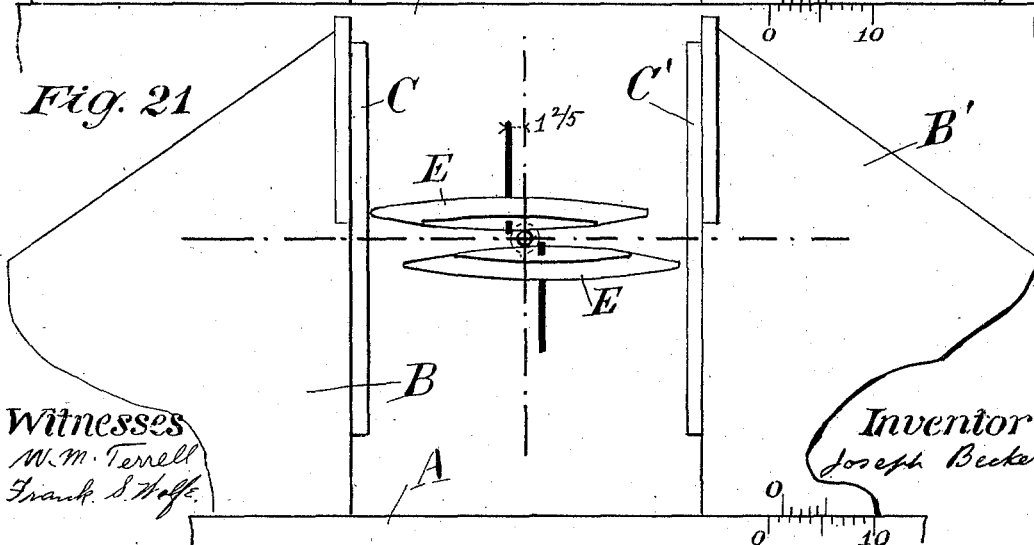
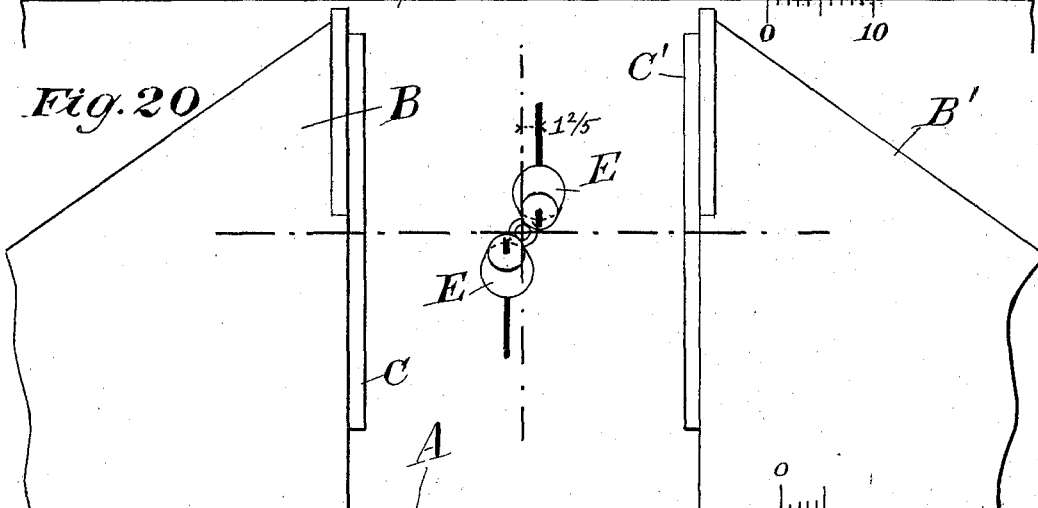
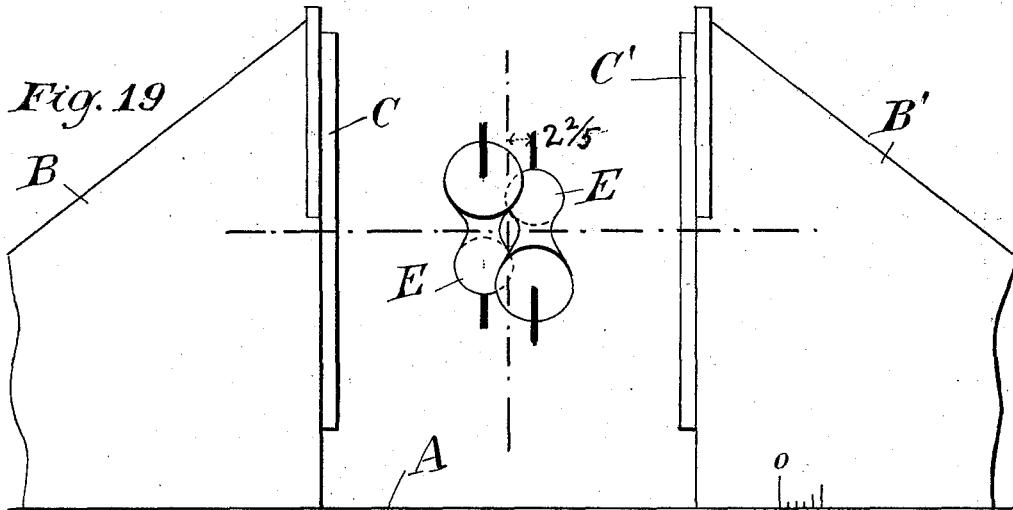

Witnesses
W. M. Terrell
Frank S. Hoff.

Inventor
Joseph Becker

J. BECKER.

SEAMLESS TUBE ROLLING MACHINE.

(Application filed May 12, 1900.)

(No Model.)

21 Sheets—Sheet II.

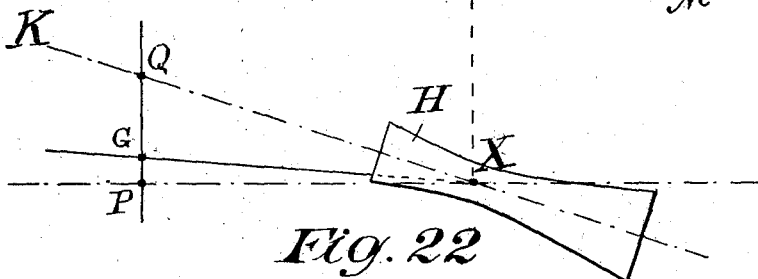
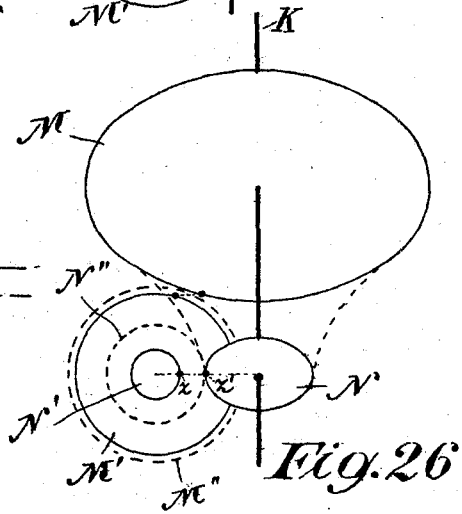
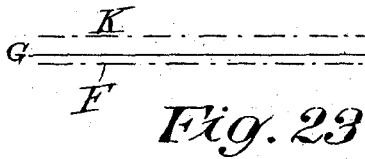
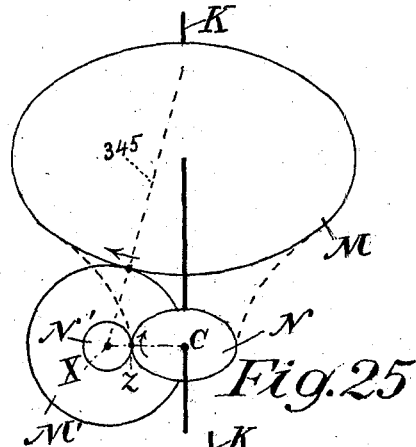
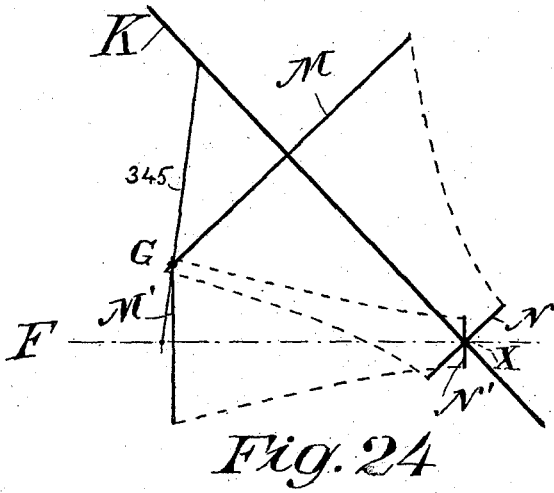

Witnesses.
W. M. Terrell
Frank S. Wolfe

Inventor
Joseph Becker

J. BECKER.

SEAMLESS TUBE ROLLING MACHINE.

(Application filed May 12, 1900.)

(No Model.)

21 Sheets—Sheet 12.

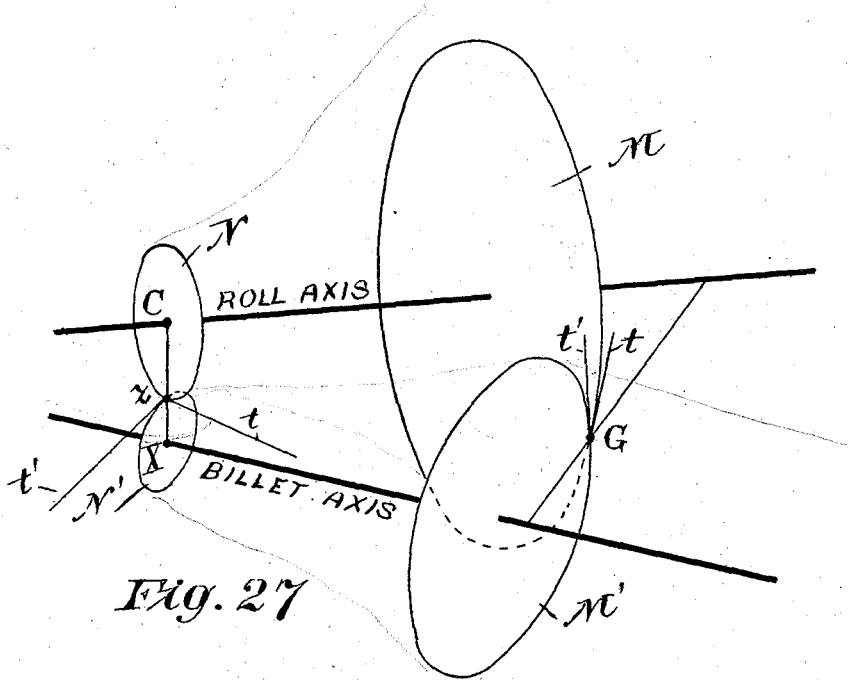

Fig. 27

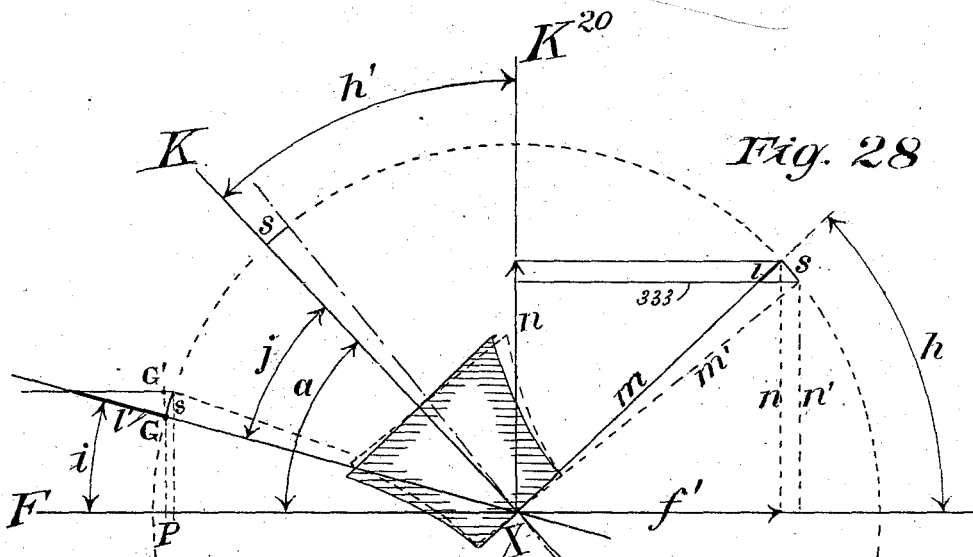

Fig. 28

Witnesses

W. M. Terrell

Frank S. Holge

Inventor

Joseph Becker

J. BECKER.

SEAMLESS TUBE ROLLING MACHINE.

(Application filed May 12, 1900.)

(No Model.)

21 Sheets—Sheet 13.

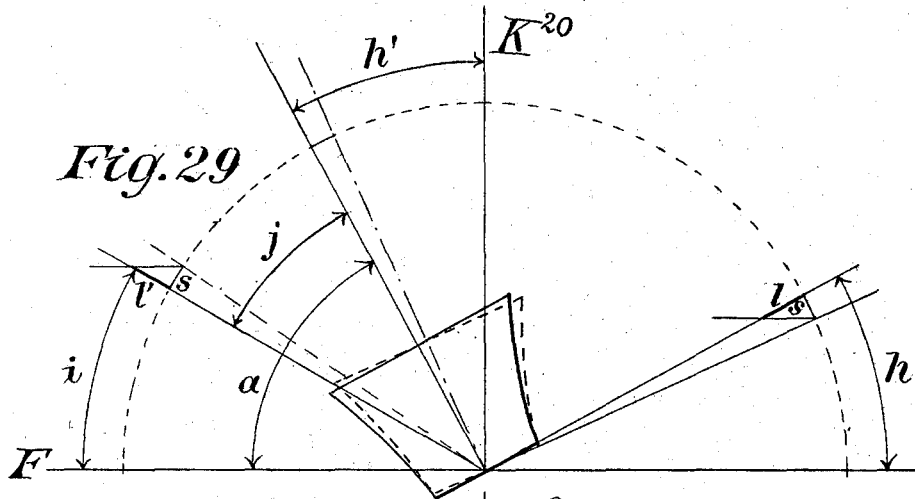

Fig. 29

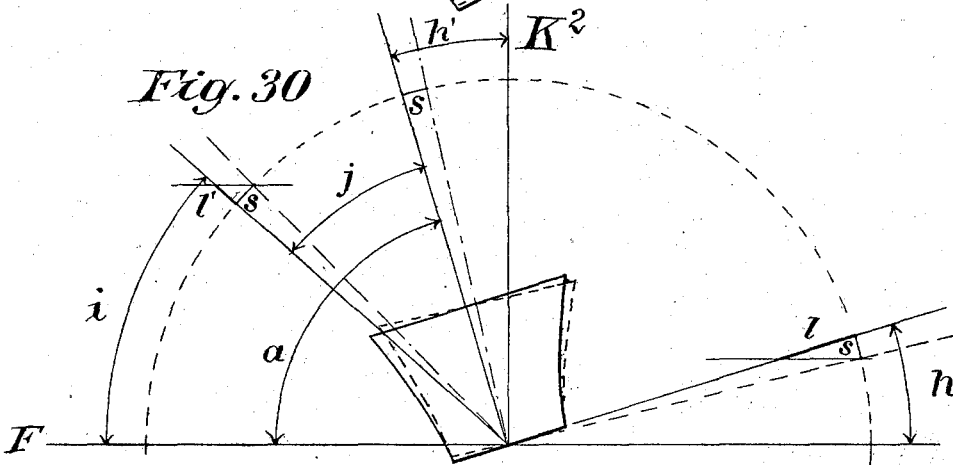

Fig. 30

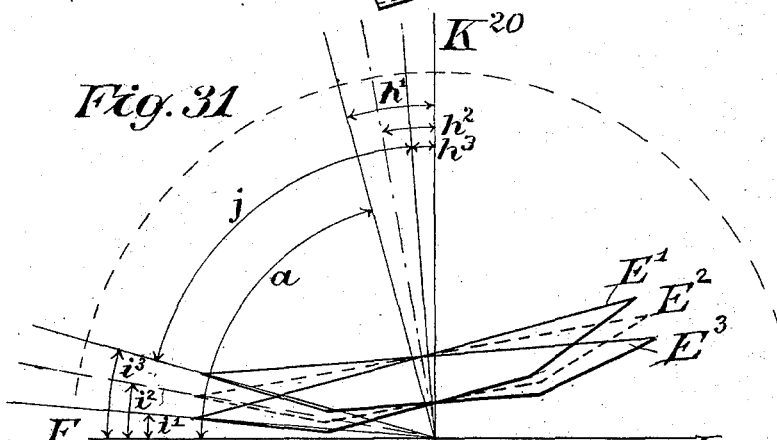

Fig. 31

Witnesses
 W. M. Terrell
 Frank S. Wolfe

Inventor
 Joseph Becker

J. BECKER.
SEAMLESS TUBE ROLLING MACHINE.

(No Model.)

(Application filed May 12, 1900.)

21 Sheets—Sheet 14.

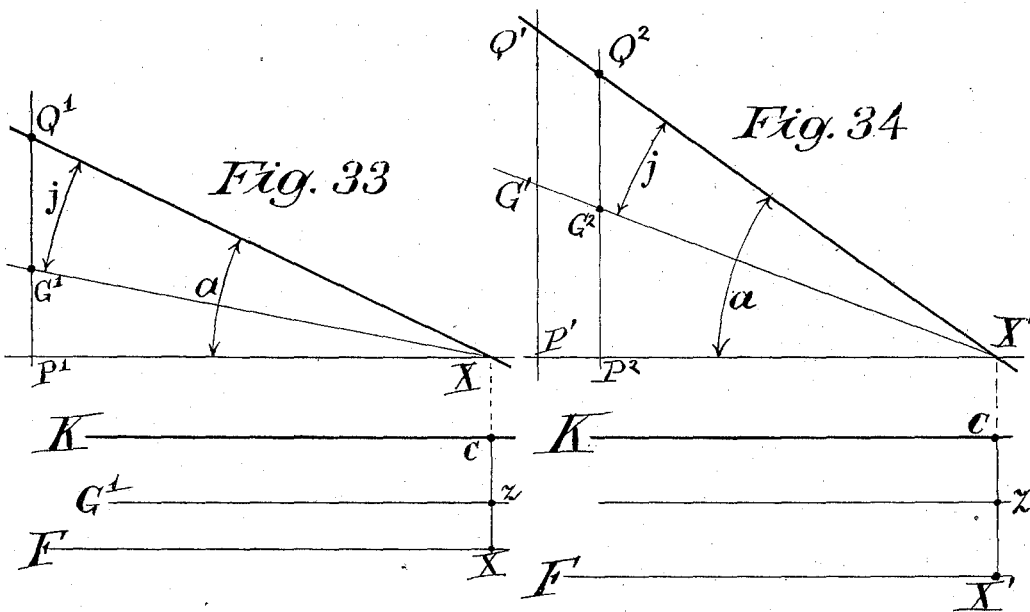
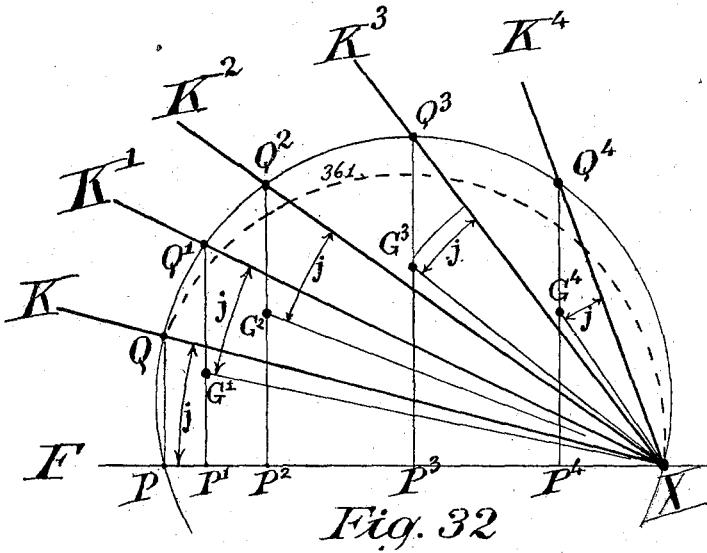

Witnesses

W. M. Turrell
Frank S. Hoffe

Inventor

Joseph Becker

J. BECKER.
SEAMLESS TUBE ROLLING MACHINE.

(Application filed May 12, 1900.)

(No Model.)

21 Sheets—Sheet 15.

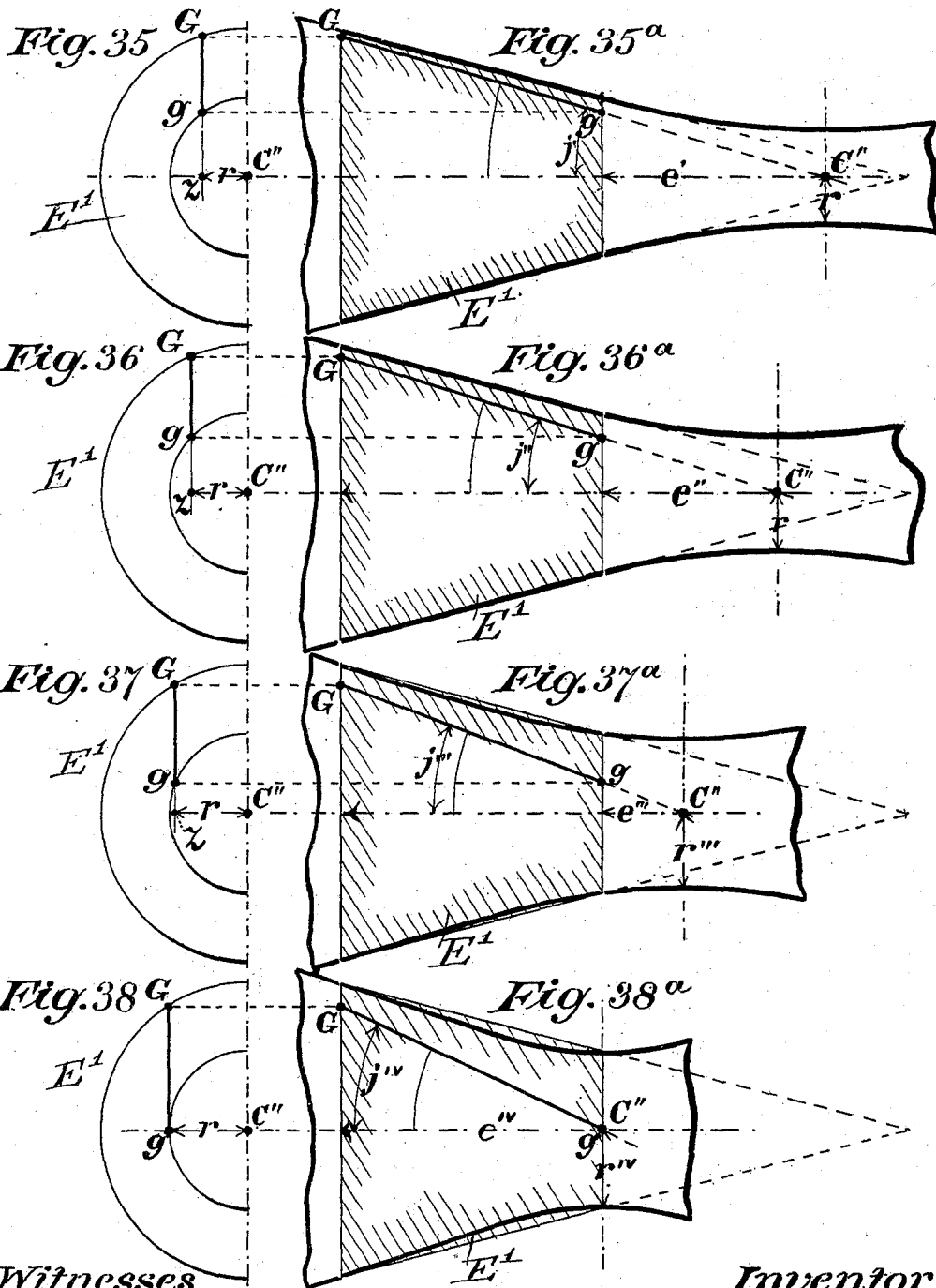

Witnesses
 W. M. Terrell
 Frank S. Wolfe

Inventor
 Joseph Becker

J. BECKER.
SEAMLESS TUBE ROLLING MACHINE.

(Application filed May 12, 1900.)

(No Model.)

21 Sheets—Sheet 16.

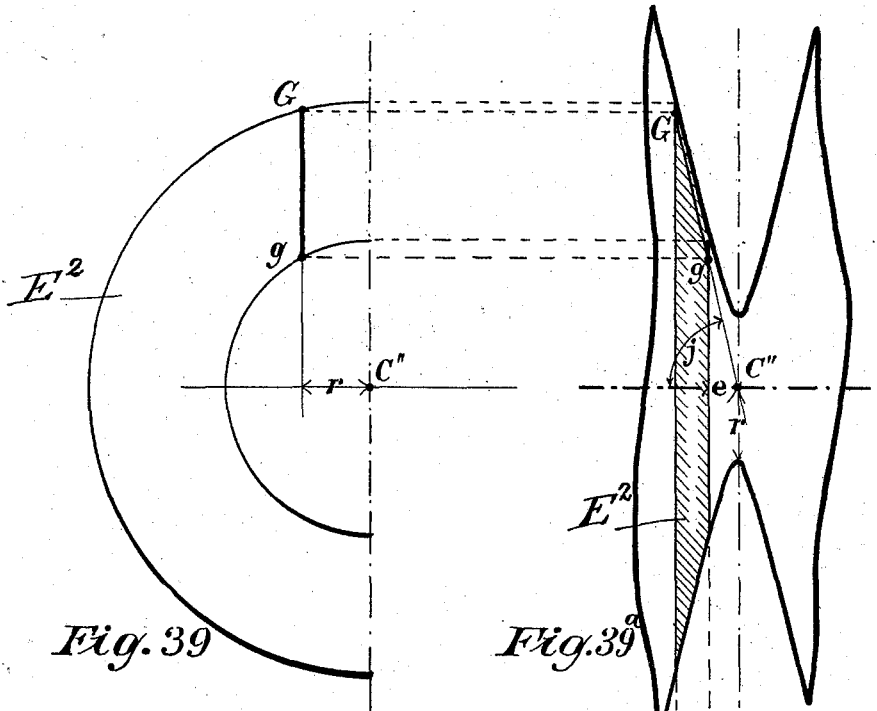

Fig. 39

Fig. 39^a

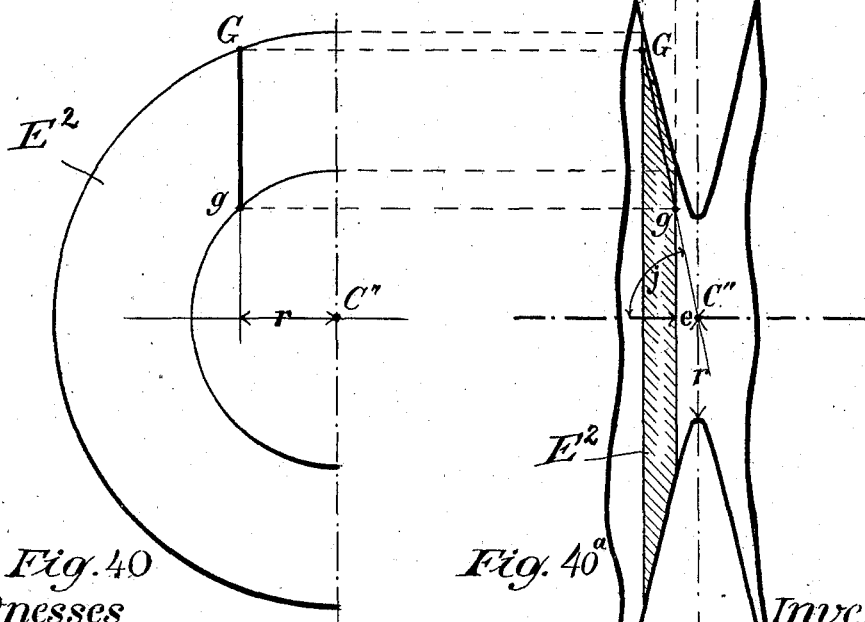

Fig. 40

Fig. 40^a

Witnesses

W. M. Terrell
Frank S. Wolfe

Inventor

Joseph Becker

No. 653,335.

Patented July 10, 1900.

J. BECKER.

SEAMLESS TUBE ROLLING MACHINE.

(Application filed May 12, 1900.)

(No Model.)

21 Sheets—Sheet 17.

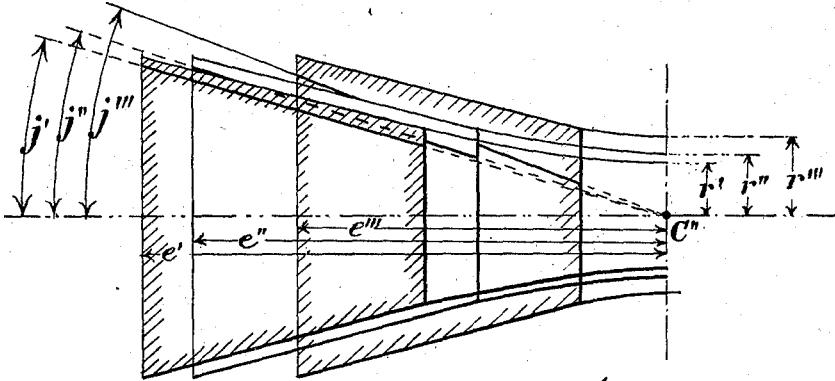

Fig. 41

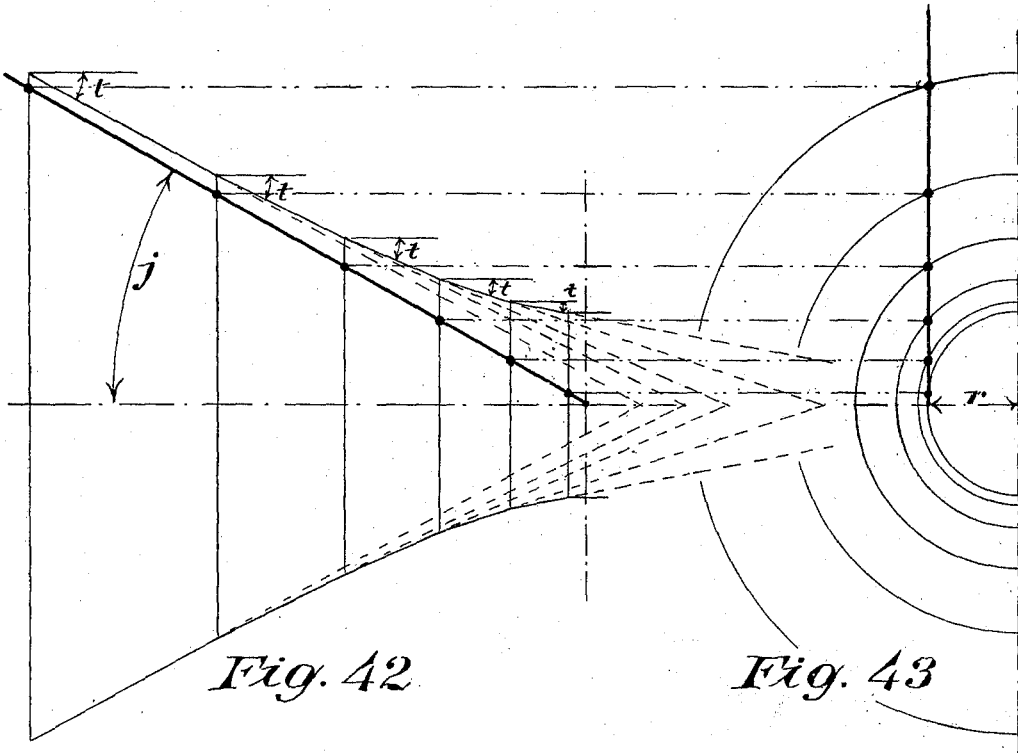

Fig. 42

Fig. 43

Witnesses

W. M. Terrell

Frank S. Wolfe

Inventor

Joseph Becker

J. BECKER.

SEAMLESS TUBE ROLLING MACHINE.

(Application filed May 12, 1900.)

(No Model.)

21 Sheets—Sheet 18.

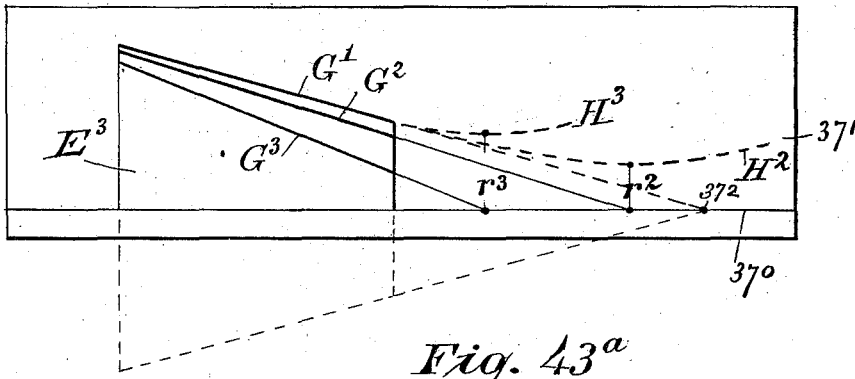

Fig. 43^a

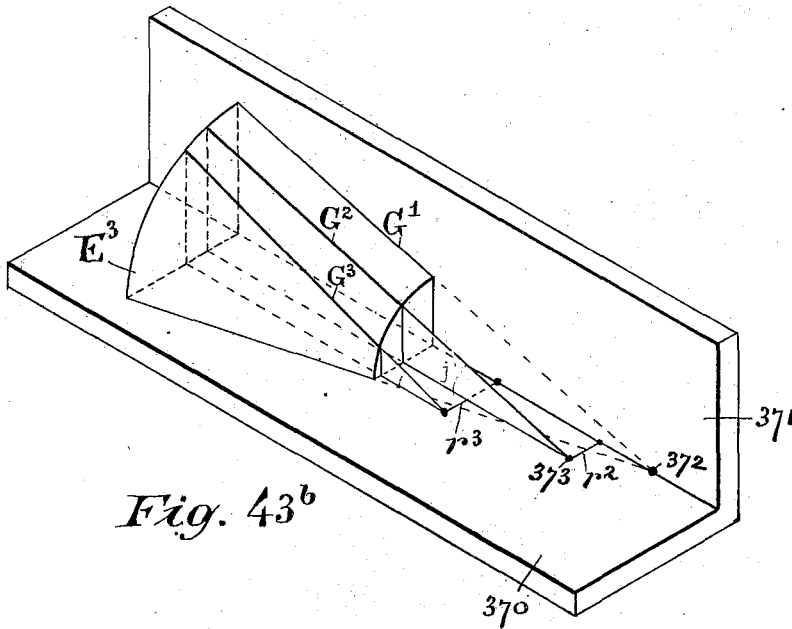

Fig. 43^b

Witnesses

Samuel Becker
Charles H. Mixer

Inventor

Joseph Becker

No. 653,335.

Patented July 10, 1900.

J. BECKER.

SEAMLESS TUBE ROLLING MACHINE.

(No Model.)

(Application filed May 12, 1900.)

21 Sheets—Sheet 19.

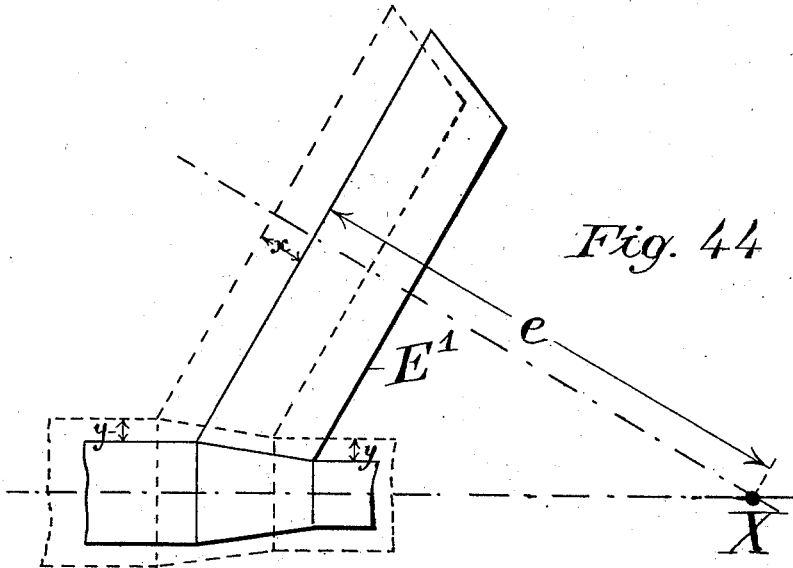

Fig. 44

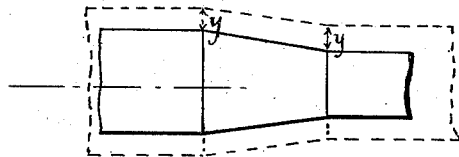

Fig 45

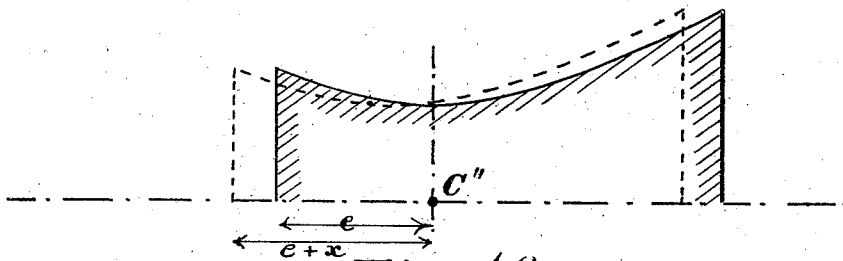

Fig. 46

Witnesses

W. M. Terrell
Frank S. Wolfe

Inventor

Joseph Becker

J. BECKER.

SEAMLESS TUBE ROLLING MACHINE.

(Application filed May 12, 1900.)

(No Model.)

21 Sheets—Sheet 20.

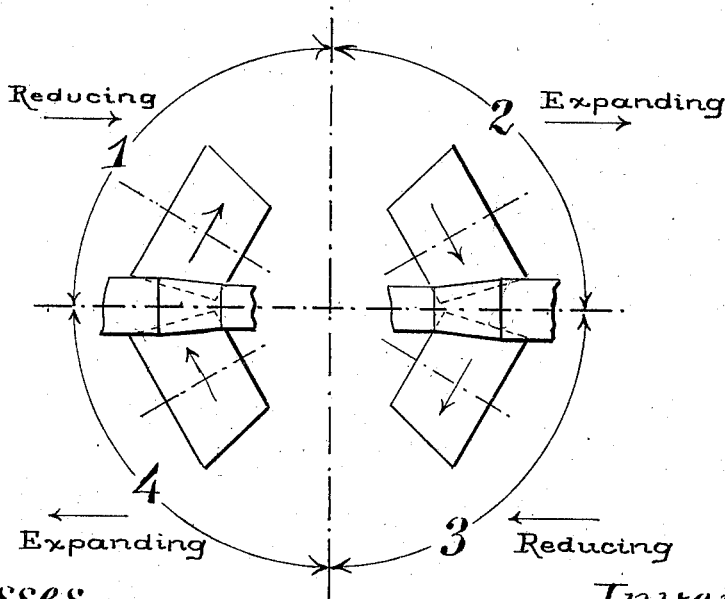
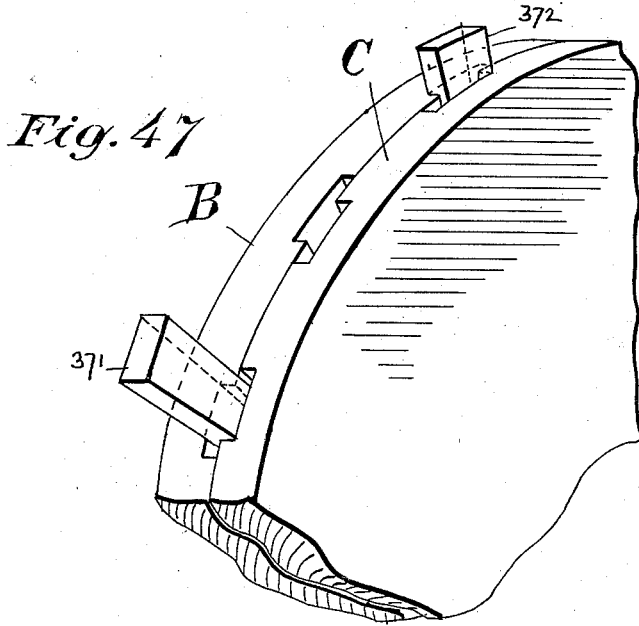

Witnesses
 W. M. Terrell
 Frank S. Wolfe

Fig. 48

Inventor
 Joseph Becker

J. BECKER.

SEAMLESS TUBE ROLLING MACHINE.

(Application filed May 12, 1900.)

(No Model.)

21 Sheets—Sheet 21.

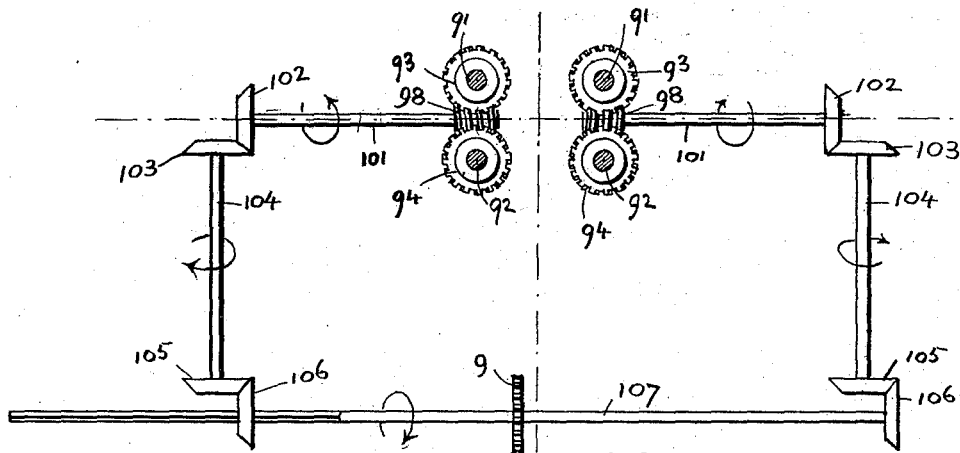

Fig. 49

Fig. 50

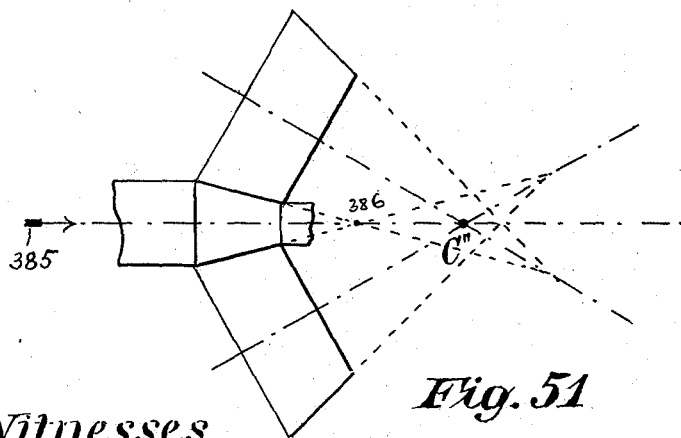
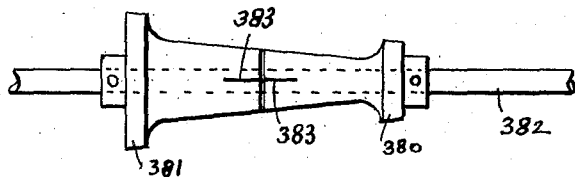

Fig. 51

Witnesses

Camille Becker
Frank S. Wolfe

Inventor

Joseph Becker

UNITED STATES PATENT OFFICE.

JOSEPH BECKER, OF WASHINGTON, DISTRICT OF COLUMBIA, ASSIGNOR TO JOHN E. SEARLES, OF NEW YORK, N. Y., AND WILLIAM C. LOVERING, OF TAUNTON, MASSACHUSETTS.

SEAMLESS-TUBE-ROLLING MACHINE.

SPECIFICATION forming part of Letters Patent No. 653,335, dated July 10, 1900.

Application filed May 12, 1900. Serial No. 16,494. (No model.)

To all whom it may concern:

Be it known that I, JOSEPH BECKER, a citizen of the United States, residing at Washington, in the District of Columbia, have invented a new and useful Universal Seamless-Tube-Rolling Machine, of which the following is a specification.

This invention relates to the Mannesmann art of rolling seamless tubes; and its object is to provide means for setting and holding any given pair of equal and similarly-acting rolls in any conceivable operative relation to secure any result the rolls are capable of—that is, to roll solid or hollow billets or blanks to form tubes or tubular blanks under all conditions of size and twist, and especially with little or no twist.

In my Patent No. 651,790, of June 12, 1900, I have fully set forth what should be the exact shape and proportion of a pair of non-twist rolls for roll-axes in a given relation. I have also set forth in such patent how these exact non-twist rolls are to be modified in shape and proportion to secure any direction and extent of twist that may be desired.

My present invention is founded on the discovery of the definite changes in size, shape, and twist of a billet due to corresponding definite changes in the relative position of the rolls, and is embodied in a machine having a special simple and limited roll adjustment, which I have discovered to be for all present purposes the full equivalent of complete universal adjustment.

My invention further consists in a special form and arrangement of rolls and in other features, all of which will be specifically pointed out in the appended claims.

In this specification I shall show that changes in the relation of rolls are in effect equivalent to changes in their shape. I shall also show that short hyperboloid zones close to the common perpendicular and long hyperboloid zones at a distance therefrom cannot be distinguished in practice from pure cone frustums having the same end circles and, moreover, that a given cone-frustum roll has almost the identical shape and proportions of a whole series of different zones of different

hyperboloids and may be used in actual practice as the full equivalent of such hyperboloid zones to roll with or without twist, that any such rolls have a whole series of positions through which they may be moved without losing their non-twisting property, and, finally, that they may be set to roll within certain limits any size and taper of billet with any degree of twist in either direction. I shall also show that any equal rolls that are to be similarly acting may be set in any conceivable operative relation by means of not more than three adjustments and that only one of these need be angular.

One of the most important features of my invention is that by its means I can determine rapidly and with any degree of precision required the value of the "coefficient of flattening" referred to in said other patent. This coefficient defines the relation between what I have called my "theoretical roll" or roll acting on a billet, the cross-section of which is supposed to remain perfectly circular, and my "practical roll," which is a modification in shape of the theoretical roll to allow for all departures of the billet from a circular shape. The coefficient derives its name from the most important of these deformations, which is that due to the flattening of the billet under the pressure of the rolls. The value of this coefficient of flattening depends on the degree of convergence of the pass, the temperature of the metal operated upon, its physical properties at and about that temperature, and finally on the cooling effect, which is in turn dependent upon the relative size of rolls and billet, the absolute size of the billet or its extent of surface per unit volume, and the speed of the rolling operation. This coefficient therefore is a highly-complex composite of physical constants and may itself be considered as a physical constant the value of which is most easily determined by direct experiment. The obvious way of conducting such experiment is to try a series of differently-shaped rolls in which the coefficient goes gradually increasing; but, as I shall show hereinafter, the same coefficient may be very quickly found by proper changes in the

relation of a single pair of rolls, and hence my present invention is a very useful complement of the other.

I do not believe that any rolling-machine has ever been made with rolls that can be adjusted into any desirable relation, and I do not believe that any person has ever described how rolls could be made universally adjustable or has ever before correctly stated how many and what kinds of elementary adjustments are required to place a roll in any desired position. Finally, I do not believe that any person has ever accidentally hit upon a combination of adjustments that might be the equivalent of mine, for it will be noted that it is not sufficient that the adjustments be of a certain number and of a certain kind, but any one must bear a certain relation to the others, so each shall be the exact complement of the others.

While the general desirability of a universal adjustment would be recognized by any person, I believe no person has ever before realized the possibilities of such adjustment, the most important of which is, as stated above, that a given pair of conical rolls may within certain limits be made to roll a billet of given shape and size with a given degree and direction of twist.

True universal adjustment of a roll, as I shall show, requires five separate adjustments, of which two must be angular. When it is considered that any additional adjustment calls for complication of supports, specially-designed means of communicating motion from the fixed source of power, multiplication of gearing, and consequent introduction of much lost motion, the simplification attained by suppressing two adjustments in five, without counting the saving in trouble and expense, is of the highest practical importance.

I have not only found that the adjustment may be a limited one, but that it may be such as to convey, by means of three simple expressions—"angularity," "offset," and "eccentricity"—which I have coined for the purpose, an idea of the exact position of a roll as definite and clear as that given by the terms "latitude" and "longitude" used to define the position of a point on a map.

A roll would be universally adjustable within a certain space if a given point of its axis could be placed wherever desired in such space and the roll-axis angularly adjusted about such point as a center to point in any possible direction.

The position of a point may be determined by three rectilinear factors corresponding to latitude, longitude, and altitude as used in geography, and three rectilinear adjustments corresponding to these factors may be used to place a point wherever desired within the limits of adjustment. Having fixed the position of a point of the axis, the axis may be set in any desired direction by means of two angular adjustments about the fixed point as

a center on axes which intersect at right angles in a manner similar to that found in telescope-mountings. By means of these three rectilinear and two angular adjustments a roll might be placed wherever desired and pointing in any possible direction, and therefore would be universally adjustable in the strictest sense of the term, and any roll that has less than these five elementary adjustments cannot possibly be a universally-adjustable roll. Therefore I do not claim rolls set by my method to be universally adjustable; but what I do claim is that they can be set to do any work that they possibly could do if they were universally adjustable—that is, they can be set by my three special adjustments to roll a billet of any size, shape, and degree of forward or backward twist that they could be made to roll by absolute universal adjustment.

In the accompanying drawings, in which the same reference-signs indicate similar parts, Figure 1 is a general plan view of the mill with the turn-tables, rolls, and roll-carriage removed. Fig. 2 is a side elevation with the left half in longitudinal section and one turn-table and its carriage removed, but showing the two rolls in one of their proper relations. Fig. 3 is a transverse section on the line 3, Fig. 2. Fig. 4 is an end elevation showing the gear that controls offset. Fig. 5 is a section of the turn-table and adjacent parts on the line 5 of Figs. 6 and 7. Fig. 6 is a full face view of the turn-table and roll-carriage, the roll being removed and part of the roll-shaft broken away. Fig. 7 is a section on the line 7, Fig. 6. Figs. 8^a, 8^b, and 8^c are respectively an elevation, a plan, and an end view of a pair of rolls and their interposed billet and are principally given to show the three factors of relation—angularity α , eccentricity e , and offset o . Figs. 8^a to 51 are diagrams which will be described in detail where again referred to.

In order to be understood, I must first explain a simple, thorough, and scientifically-accurate method which I have devised for defining roll relations.

Roll Relations.

I have taken as basis of relations the axis of the billet, which though a purely-imaginary line has an absolutely-certain position for any given combination of rolls and bears a certain definite relation to every roll of the combination, and which therefore if supposed fixed in position may serve to place the rolls in proper relation to itself and to each other. The shape and size of a billet and the action of a roll thereon clearly depend on nothing else but the shape and size of the roll and its relations to the billet-axis. I shall describe the billet-axis throughout in its usual position, which is horizontal.

The relation of a roll to the billet-axis may be certain and known, but is very hard to define, because in all tube-rolling machines of

the kind my invention relates to the axis of the roll and the axis of the billet never intersect and are never parallel, but cross without meeting and have no common plane or common point of reference. Any change in the point of view changes their apparent inclination and their apparent point of intersection.

Suppose F, Fig. 9, to represent a billet-axis seen end on, and E a roll. The axis K of this roll when produced passes by F without meeting it, and the difficulty of defining the position of the roll involves two others—namely, defining the position of the roll-axis and then the position of roll E on such axis. While lines that thus cross without meeting have no plane in common and no point in common, they have, as proved in treatises on geometry, a common perpendicular. There is a third line, and only one, which meets the two given lines at right angles. This common perpendicular is easily found in the diagrammatic end elevation, Fig. 9, by dropping a perpendicular $F C''$ from F onto the projection of the axis K. The part of this common perpendicular which lies between the axes is seen full size in this end view and represents what I have called the "offset" of the roll-axis, because said axis may be supposed to have been "laterally translated" or offset from an original position K' , intersecting F, to its actual position K. The amount of offset is measured in any linear unit and is represented by abbreviation o .

To show a roll-axis in end view, all that is necessary is to know the direction and amount of its offset. Thus there is no difficulty in drawing the end view, Fig. 9, in which the direction of the offset is d degrees from the zero or downward vertical position (one hundred and ten degrees in the figure) and its amount a certain number of inches, (represented by o .) A roll-axis thus represented may, while preserving the same projection in the elevation, occupy any angular position in the plane perpendicular to $F C''$ at C'' —that is, it may be turned on $F C''$ as an axis to generate said perpendicular plane—the whole of which would appear in this elevation as a line K. There is one position of the axis K in said perpendicular plane when it lies parallel with the billet-axis F and appears in the end view as a point, and therefore bears no angular relation to F. This position is what I call the "zero" position of "angularities," and I have called "angularity" of the axis the angle through which the axis must be slued to carry it from the zero position to its actual angular position. Angularity is measured in degrees and its amount is represented by a . The angularity and the axes appear actual size—that is, unmodified by perspective effect—in a side view, Fig. 10, taken in the direction of the common perpendicular, as shown by arrow 298, Fig. 9. In such view the offset is seen as a point, and the axis F coincides with the zero of angularities, and

the axes apparently intersect at an angle a degrees equal to the angularity. The apparent point of intersection is the end view of the common perpendicular, and hence shows where the common perpendicular meets the two axes. The distance f of this apparent intersection from any fixed point of origin, as X, on the billet-axis, is the last factor necessary to fully determine the absolute position of a roll-axis. The difficulty of defining the position of the roll on said axis now vanishes, because the fixed point C'' , determined by the common perpendicular, may be used as a point of reference. The distance from such point C'' to any well-defined point of any kind of roll is what I have called (for reasons to appear later) the "eccentricity" of the roll. Eccentricity is measured in any linear unit, and its amount is represented by e .

It is important to note the direction in which a roll faces when it is brought back to zero angularity; but this precaution may be dispensed with, if the eccentricity is provided with the algebraic plus and minus signs. An eccentricity of plus e inches would then be understood to indicate that the roll faces one way, and an eccentricity of minus e inches would indicate that the same roll has the same eccentricity as before, but faces the opposite way. The eccentricity may be changed from plus to minus without reversing the roll by adjusting it through and beyond the common perpendicular.

The conical rolls that will be referred to later on in this case all face in the same direction, and their eccentricity is measured to the centers of their base or threaded ends, (see Fig. 8^a.) because the centers of these ends of the different rolls all bear when the rolls are mounted the same relation to the roll-carriage.

I have not given any special names to the factors d and f , because I do not refer to them very often and do not wish to needlessly burden my case with special terms.

A very clear idea of the five factors of relation $f d$, offset o , angularity a , and eccentricity e may be got from the perspective diagram Fig. 11, in which the billet-axis F is represented as the upper horizontal edge of a vertical plane 301, resting on a horizontal plane 302, the planes being added merely to give a clear idea of directions. In this view let 303 represent a roll in any given position and let the axis of this roll be produced to C'' , where it is met by the common perpendicular—that is, by a line which meets said axis at right angles and which also meets the billet-axis at right angles. The distance e in inches from C'' to the large end of the roll is the eccentricity. A line 300, parallel to the billet-axis F, represents the zero of angularities for this particular roll-axis, the angularity of which is represented by a , measured in degrees. The direction d of the offset o is measured in degrees from the vertical radius 299, and the distance f inches of the common

perpendicular from the fixed origin X on the axis F is what I have referred to as "factor" f . The distance f inches, direction d degrees, and amount o inches of the offset fully determine the point C'' of the roll-axis. The angularity a degrees determines the roll-axis, and the eccentricity e determines the exact position of the roll on its axis, and hence also its position with relation to the billet-axis and to the planes of the diagram. Thus I am enabled to accurately define in plain words without the aid of any diagram or illustration the exact position of any roll.

To fully determine the position of a roll, the five variable factors are indispensable, and therefore no roll can be made universally adjustable with less than five independent elementary adjustments corresponding to the five factors of relation, and this I have found to be the case by several different methods of placing rolls.

One of my principal discoveries is that for the purpose of my present invention two of these adjustments are not necessary. The factors which I have designated as f and d may remain constant, because any variation in either or both of them acts on the billet as much and in the same manner as it acts on the roll, and therefore does not change the result and has no more effect than would have a bodily adjustment of the whole machine. This is strictly true of any one roll considered by itself with its billet and is evidently true also of any number of equal cooperating rolls whose factors f and d should remain constant, or if varied should be equally varied in all; but the principle would not be true where two given rolls for any reason would have to have a variable difference in their f factors or in their d factors. With this point clearly understood no further attention need be paid for the present to more than one roll.

In the perspective diagram any adjustment of roll 303 in a direction parallel to the billet-axis which would vary the factor f and no other factor merely moves the billet on its axis in the same direction and through the same distance as the roll and does not change the shape of the billet, nor its size, nor the twisting effect. Likewise any circular adjustment of the roll about the billet-axis, as from the position 303 to the position 304, so the directional factor d is the only one changed, simply revolves the billet about its axis through the angle of displacement of the roll and has no more effect on shape, size, or twist of the billet than the preceding adjustment, which varies factor f . Finally, any combination of these adjustments has as little effect as either considered separately, and the addition of either or of both to any one or more of the other adjustments adds absolutely nothing to the results that can be got without them.

It follows that the adjustments in offset o , in angularity a , and in eccentricity e are for my present purposes alone as efficient as the five and that with these three limited adjustments

I am enabled to set the rolls of my machine not in any position and not even in any relation, but so they may be made to act on metal in any manner that they are capable of—that is, in any manner in which they could be made to act if they were universally adjustable. This conclusion seems only the more remarkable when it is noted that two of these three adjustments are rectilinear and that only one of them is angular and that (see diagram Fig. 11) making factors f and d invariable fixes the common perpendicular in position and direction, and therefore restricts the angular play to take place only in planes perpendicular to the fixed common perpendicular.

How a roll which has but one limited angular adjustment can be the equivalent of a roll having universal angular adjustment in space is fully established by the preceding demonstration; but it will make matters clearer to show this equivalence in a direct way.

In the perspective diagram Fig. 11 let 303 be a universally-adjustable roll set in any arbitrary position, and let 306 be a roll adjustable only in offset o , angularity a , and eccentricity e , and let the fixed direction of the common perpendicular be horizontal. Now, as fully explained above, the roll 303 may be slued about the billet-axis F without affecting the shape, size, or twist of the billet, and this sluing may be continued until the direction of the common perpendicular shall become horizontal, as shown, for roll 304. Furthermore, the roll 304 may also without affecting the shape, size, or twist of the billet be translated in a direction parallel to the billet-axis until its horizontal common perpendicular coincides with that of roll 306, which operation brings the roll to 305, where it is in every respect the equivalent of roll 303. Roll 306, it is clear, may by proper reduction in offset and in angularity and a certain increase in eccentricity be placed exactly in the position of roll 305, and thus becomes the equivalent of a universally-adjustable roll 303. Therefore in a universal mill, such as I would build, to have absolute control of the rolls and do with them everything that can possibly be done every roll should be adjustable in offset, in angularity, and in eccentricity. If the rolls to be used were equal or if certain effects not within the object of the present invention were desired, certain ones or all of the rolls might be adjustable to vary their factors of relation f and d , because while changes in f or in d do not in effect change the relation of a given roll to the billet-axis F they do change its relation to the other rolls. The rolls that I contemplate using in this case for the purpose of non-twist rolling are intended to have the same effect on the billet, and in order that their effects shall not have any tendency to conflict the rolls must necessarily be equal and symmetrically arranged.

To attempt non-twist rolling, as some have done, by making one roll fore twisting and the other back twisting must spoil the metal more than if it were twisted. Expressed in the factors of relation this means that the f factor of the different rolls must be identical, that the d factor must be such that the common perpendiculars shall form equal angles, and that the offsets, the angularities, and the eccentricities shall all be numerically equal and similarly disposed about the billet-axis. The f factor being identical for all, the common perpendiculars all radiate from the same point on the billet-axis and lie in a plane perpendicular to such axis and form equal angles, as just stated and as shown in the end views Figs. 12, 13, and 14, for two, three, and four rolls, respectively, and in the perspective view Fig. 15 for two rolls.

In the concrete embodiment of my invention that I shall describe hereinafter I use but two rolls, which are arranged, substantially as shown in the perspective diagram, so their common perpendiculars coincide with the same horizontal line perpendicular to the horizontal axis of the billet at a point X. The rolls are so mounted as to preserve this common perpendicular in all adjustments—that is, their angular adjustment is about a center which coincides with the common perpendicular and in a vertical plane which remains parallel to the billet-axis.

Description of the Machine.

In the machine an infinite variety of adjustments might be used to change the value of any one of the three factors of relation in any desirable manner, the only requisite being that the three factors of relation shall be known at any time by mere inspection from the extent and direction of the adjustments. As it is, however, necessary that the rolls in all possible relations shall remain at all times mechanically connected with the fixed source of power, it is better in practice to reduce the number of adjustments to the lowest possible number, and this I do by so designing my machine that each one of the three factors of relation may be varied by only one adjustment in the direction of and of the same nature as its corresponding factor of relation, and so, therefore, each adjustment shall be independent of and not affected by any of the others. Accordingly I provide one rectilinear adjustment for eccentricity, another rectilinear adjustment for offset, and, finally, one angular adjustment for angularity. Not one of these three adjustments can be dispensed with if the equivalent of a true universal adjustment is desired. For my purposes the three are therefore essential; but they are also fully adequate. No fourth adjustment of any kind is required to give the rolls any possibly desirable operative relation within the limits of the machine. Even thus restricted the adjustments permit of a great variety of arrangements, the selection of

which will depend on the general proportions and nature of the work to be done; but among all arrangements those in which the changes in adjustment do not change the position of the common perpendicular of the roll-axes lead to the simplest forms.

I will now describe a preferred form of my invention, in which the main parts are the base A, stocks B B', turn-tables C C', and roll-carriages D D', to carry rolls of any shape E E'. The carriages D D' are adjustable radially on the turn-tables C C' for eccentricity, the turn-tables C C' are adjustable angularly on the stocks B B' for angularity, and the stocks B B' are longitudinally adjustable on the base A for offset. The rolls are held as shown diagrammatically in Fig. 15, and the adjustments are such as to not disturb the common perpendicular of the roll-axes, which common perpendicular coincides with the horizontal axes of revolution of the turn-tables C C'.

The bed of the mill is a heavy rectangular open frame A, built up of castings solidly bolted together to form a substantial, stiff, and absolutely-true base. On this base the adjustable parts of the machine are, some directly and others through these, accurately set in certain desirable relations and firmly and positively held in such relations in opposition to and against the disturbing forces brought into play by the powerful reaction of the material operated upon. One of the long sides of this frame A (see Figs. 1 and 3) is perforated at its middle to admit a horizontal power-shaft 20, on the inner end of which is fixed a heavy bevel gear-wheel 21.

The motive power of the machine is derived from a shaft 10, Fig. 1, through a variable-speed gear 11 12 13 14 15 16, (shown schematically in Fig. 1,) with the low-speed gear 13 14 engaged. Beyond the variable-speed gear on the shaft 10 is a suitable clutch (not shown) for starting and stopping the machine. Within the frame A, in its longitudinal axial line and suitably fixed to said frame by cross-castings, are four plumber-blocks 22 23 24 25, of which 23 and 24 at the middle are connected on a common casting to increase stiffness. In bearings 24 and 25 lies an arbor 26, which carries a bevel gear-wheel 27, meshing with the gear-wheel 21. Integral with this bevel gear-wheel 27 is a very wide spur-wheel 28, which transmits motion from the power-shaft to the parts carried by the adjustable stock B' in the manner to appear presently. In the bearings 22 and 23, corresponding to the shaft 26 and compound wheel 27 28, are the shaft 36 and compound wheel 37 38, which serve to transmit motion from the power-shaft 20 to the parts carried by the adjustable stock B. The shaft 26, however, differs from the shaft 36 in that it is extended out to the extreme end of the machine, where it carries a bevel-gear 39 and reversing-gear 40, by means of which motion may, if desired, be imparted in either direction from the shaft 36 to 41, car-

rying worms 42 and provided at one end with a hand-gear, by means of which it may be turned by hand when delicate adjustment is required. The worms 42 mesh with two equal
 5 wheels 43 44, fixed to the ends of screw-shafts 45 46, which extend the full length of the bed A, upon which they are mounted to revolve in plumber-blocks 47. These screws may be held against endwise movement by special
 10 adjustable step-bearings; but this is hardly necessary, as there is very little, if any, tendency to displace the screws longitudinally on the bed of the machine, the strains on the screws being all balanced. Each of these
 15 screw-shafts has a right thread extending from the gear end to the middle of the machine, where the shaft is firmly held in a bearing 8, and beyond that point extending to the other end of the machine a left thread. These
 20 screws are geared with the adjustable stocks B B' by means of long and heavy divided brass nuts 48. Normally the screws remain stationary. They are never moved except when it is desired to change the offset of the
 25 rolls, which is done by adjusting the distance between the stocks B and B'. As this distance between the stocks when once set must be absolutely invariable, it is necessary before putting the machine into operation to
 30 take up any backlash that may exist in the nuts 48, and this I do by means of nuts 49, located between the stocks B B', Figs. 1 and 3, so as to put all of the strain on the nuts 48. It is clear that if these nuts 49 were
 35 located on the outside as lock-nuts against the nuts 48 instead of inside the forces acting between the stocks to spread them would have no other support but such lock-nuts.

It may be well to remark at this point that
 40 it is absolutely necessary in a machine of this kind, the work of which is materially affected by the slightest give or vibration in any part of the structure, to pay attention to the exact manner in which the locking parts operate.
 45 Ordinarily whether parts are locked in one direction or another does not make much difference; but throughout this machine wherever possible, and as shall appear later on, all clamps are set and designed so as to
 50 act in the direction of the stress due to the reaction of the material operated upon.

The stocks B B' are pyramidal castings. In side view they are shaped and act like
 55 U form, with the legs spread to rest upon the longer sides of frame A. These sides of the frame are planed on their upper faces and provided with a V-rib 50, which engages with a corresponding V-groove in the stocks. Between the legs of the stocks are bolted cross-braces 51, 52, and 53 to carry the bearings for the different shafts which are to be mounted in and carried by the stocks. The
 60 braces 52 and 53 carry a non-revoluble arbor 54, which projects beyond the face of the stocks as a pivot for the turn-tables C C'. This fixed shaft also carries, to revolve freely

thereon, a spur-gear 55 and a bevel-gear 56, fixed to revolve together and preferably made integral. Meshing with the spur-wheel of
 70 this combination and below the same is the spur-wheel 57, which is mounted in the cross-braces 51 52. This last wheel 57 extends well below the stock down into the base A, where it meshes with its corresponding spur-wheel
 75 28 or 38 and remains in engagement therewith through all adjustments of its stock, owing to the fact that said spur-wheels 28 and 38 are made of a width equal to that of the spur-wheel 57 plus the distance through which
 80 the stock may be moved. It would be possible, of course, to make the wheels 28 and 38 of the same width as wheels 57 and to spline them on their shafts, so that they might follow the lateral movements of wheels 57; but such
 85 a structure is not considered as substantial, simple, and reliable as the one illustrated.

The turn-table, Figs. 5, 6, and 7, to make the parts carried by it more accessible and to make it stiffer, is dished. It consists of a
 90 rim 60, a hub 61, and a web of general conical shape connecting the hub and the rim and modified to depart from its general conical shape when necessary to form suitable slides and supports for the roll-carriage and the
 95 auxiliary parts. The hub 61 of the turn-table fits snugly on the projecting end of the non-revoluble shaft 54, and the rim 60 is adapted to bear all around against the flat inner face of the stock, which is provided with
 100 arcuate slots 62, corresponding to similar arcuate slots 63 on the rim of the turn-table, these slots being all equal and separated by a distance equal to the length of one of the slots less their width. The rim is to be firmly clamped
 105 to the face of the stock, so as to be virtually a part thereof, by means of stout bolts passed through where the slots of the rim and those of the stock overlap. By this arrangement of openings there is provided a great latitude of
 110 adjustments without materially weakening the parts to be connected, and, furthermore, as the clamp-bolts are distributed on a circle of greatest possible radius and the reactions of the material are all well within this circle the
 115 bolts have an immense purchase and advantage over the disturbing forces. If, however, greater rigidity be desired, this can readily be secured by providing the face of the stock with a series of grooves having radial walls
 120 and the rim of the turn-table with a corresponding series of similar grooves differently spaced, so that it shall always be possible to insert radially two wedges 371 and 372, Fig. 47, acting in opposition and preventing absolutely any angular play of the parts. This
 125 extra precaution is hardly necessary in ordinary cases when the parts are sufficiently held against displacement by the friction due to the pressure of the bolts by the fixed shaft
 130 54 and finally by a worm 64, mounted snugly between projections 65, cast integral with the stock and engaging teeth 66, Fig. 6, cut in the rim of the turn-table. The worm is used

primarily to rotate the turn-table on the stock; but if well fitted it is also a very efficient means for locking the table in any desirable angular position on the stock. The worm-shaft 5 66½ extends downwardly to and through a bearing 67, where it is provided with a bevel-gear 68. This gear meshes with another bevel-gear 69, the hub of which is extended to form a short journal mounted to revolve in a bearing 10 fixed, like the other, to the stock. The short journal is provided with a collar, so the bevel-wheel shall be carried along with the stock and remain in fixed relation thereto. This wheel and its journal extension have a square axial perforation, in which is fitted to slide a square horizontal shaft 71, held against longitudinal motion in bearings 72, carried by the bed A. This shaft connects the two worm mechanisms of the two turn-tables, and thus insures equal angular displacement of said turn-tables. The worm 64 and their gearing are designed so that when one table is turned one way the other will be turned the opposite way. The horizontal shaft 71 is provided with means, such as a lever 73 and wheel-gear, Fig. 3, for rotating it to set the turn-tables in any desirable angular relation.

On each turn-table is mounted a roll or disk carriage D, comprising a heavy rectangular open frame with dovetail sides 80, Fig. 7, and extensions 81 and 82, forming bearings for a roll-shaft 83, which is provided between these bearings with thrust-collars 84 and 85, that maintain it in fixed longitudinal relation to the carriage. When the rolls have to be brought so close that their shafts might interfere, the shaft 83 cannot be extended to the bearing 82. In this case the collar 84 is transferred to 86. The adjustable step-bearing 88 is an equivalent for the collar 84. The carriage is mounted in a dovetail radial slide-way, in which it may be set at any desirable point by means which I shall now describe. To the carriage are firmly fixed by clamp-plates 90, Fig. 5, two parallel screws 91 and 92, one of which has a left thread and the other a right thread. These screws do not revolve and may be considered as a part of the roll-carriage. On the screws are the nuts 50 93 94, which are sunk into the turn-table in recesses 95 96, Figs. 6 and 7, in which they are free to turn, but are prevented from taking motion in a direction parallel to the screw-axis. The end walls of these recesses 95 and 55 96 have extensions 97 to give the nuts a better thrust-bearing. Caps may be added, but are hardly necessary. The nuts have a central expansion, in which is cut a worm-thread, with which engages a common worm 98, which 60 must be held against endwise motion, and for this purpose is mounted in a stirrup 99, bolted to the turn-table by cap-screws 100, Fig. 5. The stirrup is perforated to admit a shaft 101, the end of which, by squaring or 65 some equivalent means, is adapted to be slid into the worm to revolve it. The shaft 101 extends longitudinally through the fixed shaft

54 and carries at its outside end a bevel-gear 102, meshing with a bevel-gear 103, connected by shaft 104 with a bevel-gear 105, which 70 meshes with gear 106. The gear 106 of the one stock B is connected with the gear 106 of the other, B', by a shaft 107, Fig. 49, which may be fixed to the one gear and adapted to slide through the other, as shown, with spline 75 connection. The shaft 107 may be revolved in the same manner as shaft 71 by a lever and wheel-gear 108. Revolution of shaft 107 by the means described revolves the two worms 80 simultaneously and equally and through them turns the nuts 93 and 94 in the proper direction to displace the roll-carriages D and D' equally on the turn-tables. The worms should revolve oppositely, for reasons given later. To take up any backlash after the carriages are 85 set and to firmly hold the carriages against longitudinal vibrations, I provide a clamp-screw 117, by means of which the carriage is forced against its adjusting means in the direction in which it tends to move under the 90 reaction of the billet. This is in accordance with the principle enunciated above. When the carriage has been set where desired, it must be firmly clamped to its turn-table. This I do by means of a longitudinal wedge 95 109, which is drawn tight by a nut 110 and may be drawn loose, when desired, by a nut 111. Of course before any attempt is made to change the adjustment of the carriage all clamps must be well opened. The wedge 100 is preferably placed on the under side of the carriage for the upper roll and on the upper side of the carriage of the lower roll unless the rolls be tandem rolls or unless they be my special continuous piercing and expanding 105 rolls, when there is no preference, because in this case the carriage-tilting forces in the piercing zones act in opposition to those in the expanding zones.

In Fig. 5 I have shown in full lines a roll E 110 of the general shape of a truncated cone. It is firmly screwed home on the roll-shaft, the thread 112 being in the proper direction to be tightened by the reaction of the work. If it be desired to reverse the direction of rotation 115 to use the rolls as expanding-rolls, it will be necessary to have some connecting means that will be a positive lock in either direction; but the screw being a preferable means of connection, and also to avoid the necessity of 120 reversing-gear, I prefer to convert the rolls into expanding-rolls without changing their direction of rotation. How this may be done is seen in Fig. 48, where the whole region that may be occupied by roll is divided into quad- 125 rants 1, 2, 3, and 4. When the roll is in the uneven quadrant 1 or 3, it is reducing; when in the even quadrant 2 or 4, it is expanding; when above the billet-axis in quadrant 1 or 2, it feeds to the right; when below in quad- 130 rant 3 or 4, it feeds to the left. A same roll may therefore, without change in rotation, be used to reduce and feed either way or to expand and feed either way, and to secure these

different results in my machine all that need be done is to carry the worm-teeth 66, Fig. 5, all the way around the turn-table C and multiply the bolt-slots 62, Fig. 3, in the stocks B 5 B'. If the direction of feed be immaterial, the range of adjustments to make a same roll revolving in the same direction either a reducing-roll or an expanding-roll need not exceed one hundred and eighty degrees; and if 10 the rolls are to be used only for the purpose of reducing or for the purpose of expanding, a range of about sixty degrees will do for all proportions of rolls.

The roll-carriage between its bearings being made long enough to take, in addition to the piercing-roll, an expanding-roll, it is desirable with heavy work to steady the roll-shaft by adding a middle rest or bearing, which is very necessary when the expanding-roll is used. When my continuous piercing 20 and expanding rolls are used, they are themselves generally heavy enough at their weakest point to not need such steadying. If they should, however, need it in special proportions that do weaken them much, the steady-rest is provided with wheel-bearings. (Not shown.) The rest is shown dotted in Fig. 7, and is simply a cross-bar 113, bolted by bolts 114 to the carriage-frame, which has recesses 30 115, in which tenons on the cross-bar engage.

If the rolls used are obtuse and approximate the disk, no other bearing is needed than bearing 81; but the shaft should then have, as described above, a collar 86 (shown dotted) 35 to maintain it in proper longitudinal relation to the carriage.

The machine shown in the drawings may take rolls of any taper from zero degrees or pure cylinders to ninety degrees or flat disks; 40 but it is especially designed for so-called "cones," and could not well be used for disks unless they were small. To take disks of the usual size or to take cones that are short and of unusually-large diameters, the machine would 45 have to be made very large or else modified by making the carriage D very wide and the table C well recessed to admit the rolls or disks and give them all the swing they may need. The difficulty here is of the same kind 50 as that encountered in building lathes and is met in the same way. The roll corresponding to the work of a lathe may be long and have little diameter or short and have large diameter, necessitating a gap or break in the 55 bed. When disks are to be used exclusively, the general arrangement had better be modified to bring the roll-axes into horizontal instead of vertical planes.

The roll shown in Figs. 8^a, 8^b, and 8^c is a 60 very useful proportion of reducing-roll, because in it the thrust from the work is directed onto the main bearing and not outside of it, as in the roll of Fig. 5. This is a very useful feature, because it is mechanically better and also because it permits of setting the 65 rolls as close as may be desired in offset. The beveling of the smaller end of this roll is use-

ful to give the work an easy exit and avoid the cutting action of a sharp edge; but this 70 bevel may be made to have a very useful sustaining, rolling, and rubbing action, although it is necessarily back twisting. If it be desired to make this bevel of a certain length, its back-twisting action will have to be cured 75 by making the main part of the roll slightly fore twisting, or, which amounts to the same thing, by setting the roll so it will be non-twisting as a whole. This very useful form of roll is the equivalent of my true non-twist 80 roll, Fig. 8^d, with a slight swell (shown dotted) near its smaller end, and differs from my complete hyperboloid reducing and expanding rolls in that the expansion occurs before 85 instead of beyond the common perpendicular, and therefore in that the rolling never can be wholly without twist; but the amount of twist may be made very small by making the diameter of the roll large, so that the swell, which would be constant for a same billet, will add 90 as little percentage as possible to the length of the roll radii. The roll-shaft being easily removable, any special shaft may be used, and, if preferred, the rolls may be invariably and solidly connected with their shafts and removed therewith, each roll having the shaft 95 best suited for it. The shaft may have any desired proportions between the bearings. In all cases, however, it should have the equivalent of a good thrust-collar and an end shaped to fit exactly in the adjustable step- 100 bearing. In this manner the shaft is firmly mounted in the roll-carriage close to the main bearing and the roll is firmly fixed to the shaft, so that the relation of the roll to fixed parts of the mill shall when once established remain 105 absolutely invariable. It is plain that this absolute invariability could not be preserved if the shaft were simply splined to the roll, which would be the most obvious way of mounting it for changing eccentricity. As 110 the shaft follows the carriage in its adjustments, it becomes necessary to provide somewhere between the carriage and the driving mechanism the equivalent of a splined connection. This may be done in a variety of 115 ways. I prefer to produce the shaft 83 well beyond its bearing, making it square in cross-section to receive motion from a gear-wheel 120, which is provided with hub extension 121 and a retaining-collar 122, held in a bearing 120 123 on the turn-table, so as not to slide with the roll-shaft. This gear-wheel 120 might have an inner hub extension and an inner bearing; but this is not necessary and is to be avoided when possible, because it 125 reduces the range of adjustment of the roll-carriage on the turn-table.

In the turn-table is mounted a short counter-shaft 124 for a pair of integral gears 125 126, the one, 125, being a spur-gear to mesh 130 with the spur-gear 120 of the roll-shaft and the second, 126, a bevel-gear to mesh with the large central bevel-gear 56 on the fixed arbor. As the turn-table is revolved to change the

angularity of the rolls the bevel-gear 126 will at all times remain in engagement with the central bevel-gear 56, and thus preserve connection with the source of power for all angularities of the rolls. When it is possible to make the gear on the roll-shaft large enough, or when the framing is designed to permit of bringing the central gear closer to the roll-shaft, the roll-gear may be made a bevel-gear engaging directly the central gear without the intermediate counter-shaft.

Power is transmitted from shaft 20 through bevel-gears 21 27 37 to the long spur-gears 28 38. These, whatever the offset, revolve the wheels 57, and these wheels 57 in turn revolve the central compound gear 55 56. The bevel-gear 56, whatever may be the angularity, revolves the roll-gear 120 through the compound gear 125 126, and finally the roll-gear 120, whatever be the eccentricity, revolves the roll. Moreover, any one of the three roll coördinates a o e may be changed without disturbing either of the others. o and a and o and e are made independent by spline connections at 69 71 and at 106 107, Fig. 2. To make the e gear entirely independent of changes in a , it would be necessary to effect adjustment in e by means moving longitudinally of the axis of the turn-tables. A rotary motion being preferable, I devised the e gear described above, which moves during changes in a , but not in a manner to change e or to be at all objectionable. The principle involved is that the worms 98 to remain in fixed relation to the turn-tables during a change in angularity should revolve with them, and to permit this action I have designed the device so that the worms should be geared together to revolve oppositely in the same manner as the turn-tables.

Use of the Machine.

My machine may be used to hold any pair of equal rolls in any possible symmetrical relation to the billet-axis, and so therefore they may be set to produce any degree of twist that they are capable of producing; but my principal object in this case being to roll with little or no twist I shall restrict myself to those arrangements which secure such result.

Before explaining the use of the machine with rolls having the shape of cone-frustums—that is, with either so-called “cones” or so-called “disks”—I shall first explain its use with the pure hyperboloidal rolls of my Patent No. 651,790, because cone-frustums, whatever their proportions, can be non-twisting only when they approximate in shape, size, and relation certain ones of my non-twisting hyperboloid zones. I have shown in said patent that non-twist rolls of unlimited length for axes in a given relation have the same general proportions as the space which lies between the given axes—that is, they are smallest at the common perpendicular or in the region of closest approach of the axes and go gradually increasing either way from such

region—and as it is always possible to construct an exact hyperboloid having the same larger circles and the same smallest circle as a true non-twist roll and differing very little from the true roll at all intermediate points I found it convenient to treat the rolls as exact hyperboloids. It is well known that a hyperboloid is generated by a straight line revolved in fixed relation to and about an axis and that such relation is all that is necessary to fully determine every element of the hyperboloid-surface, just as a given radius determines every point of a sphere. The relation of a roll-axis K to a billet-axis F being given in an elevation, Fig. 22, and a plan, Fig. 23, it was shown in said other case that a true non-twist roll for such axes is without appreciable error an exact hyperboloid-roll H , generated by a line which is perpendicular to the common perpendicular of the axes and which projects in elevation as a line GX and in plan as a line GZ , such projections being connected by the relation that the line GZ shall divide the offset at Z in a ratio CZ to ZX greater than the ratio of QG to GP , the line QP being perpendicular to the elevation of the billet-axis. The ratios would have to be equal in the case where the billet to be rolled is and remains circular in cross-section—a condition which is impossible to realize in practice, as explained in said other application; but the “theoretical roll” thus determined is very useful as a limiting case to carry on investigations. The amount by which the ratio of CZ to ZX should exceed that of QG to GP to determine the “practical roll” depends upon the amount by which the virtual periphery of the real billet exceeds the actual periphery of the ideal billet, and this amount depends on the physical constants of the metal to be rolled and on other factors, which may all conveniently be allowed for in one “coefficient of flattening,” the value of which is best determined by direct experiment. One of the most important advantages of my machine and of my method is that they permit me to conduct such experiments cheaply, expeditiously, and systematically and to make a complete scientific record of the results in the fewest and simplest possible terms.

In the diagram, Figs. 22 and 23, it is seen that the angle FXX is what I have called the “angularity” of the roll and the distance CX its “offset.” The eccentricity of such a roll is the distance e from its base of attachment to the common perpendicular or to the center of its smallest circle. The roll of Figs. 22 and 23 has an angularity of eighteen degrees and, as seen by the scale of inches on base A in Fig. 19, an offset of 2.4 inches and an eccentricity of 9.6 inches. To mount such a roll in my machine, the operator first separates the stocks $B B'$, so as to have ample room between them and the billet-guides, and as it is necessary to move the heavy stocks through a considerable distance he will preferably use power. Before applying any power,

however, he should first see that the four nuts 49, Figs. 1 and 3, are well loosened and kept from revolving by their lock-pawls 17, so they shall remain in fixed relation to the moving stocks and not be in any danger of being run down when the stocks are made to approach. To separate the stocks by power, the operator first starts the power-shaft and throws lever 18, Fig. 4, from the middle position shown to the left and keeps it there until the stocks are as far apart as he may desire. While this is doing the roll-shafts and all their gearings revolve; but as there is no objection to such motion I have not deemed it advisable to complicate the machine for the sole purpose of preventing it. The operator then stops the power-shaft and mounts the rolls on the roll-carriages D D', taking all precautions to prevent any lost motion of the shafts with respect to the carriages, and when the rolls are well in place he starts the power-shaft again and sets lever 18 of Fig. 4 from its middle position to the right and keeps it there until the stocks B B' shall be closed in to a point where they will not require too much shifting by the hand-lever 19, Fig. 4, and then stops the power-shaft. It would not be safe to move the stocks by power when the rolls are close. Having mounted the rolls, he proceeds to set them first in eccentricity, then in angularity, and finally in offset. The order is important, because it avoids any possibility of contact and interference of the rolls while they are being adjusted. The adjustment in eccentricity is got by lever 108, Fig. 3, and may be measured by direct inspection of the vernier-scale, Fig. 6, or, more accurately, by counting teeth of the wheel 9, which is revolved by lever 108. After adjusting in eccentricity each roll-carriage should be carefully clamped by screw 117 and wedge 109, and if the clamping tends to disturb the adjustment the carriages should be again adjusted, making proper allowance for the shift under clamping action. The adjustment in angularity is made by means of the "angularity-lever" 73, Figs. 3 and 4, and is measured on the scale of degrees, Figs. 16, 17, and 18, where the turn-table is shown provided with a plain index 342. If desired, this scale may also be provided with a vernier; but the finer adjustments are got by counting teeth on the wheel which is turned by the lever 73. When the rolls are properly set in angularity, the turn-tables C C' are firmly clamped to the stocks B B'. The adjustment in offset is made through lever 19, Fig. 4, and its amount is measured by means of the vernier-scale, Figs. 19, 20, and 21, or, more accurately, by counting the revolutions of shaft 41, Fig. 4. When the stocks have been set in offset, the nuts 49 are screwed up tight to prevent play, and in this, as in all other cases, the operator should verify that the reading on the scale is correct in the clamped position. By adding the usual mandrel and guides the machine is completed for operation. Any short zone of a hyperboloid-

roll, as the zone of Figs. 17 and 20, having an angularity of eighteen degrees, an offset o of 1.3 inches, (see scale on base A, Fig. 20,) and an eccentricity e of 11.5 inches, is mounted exactly the same way as if it were a complete roll having the same factors a , o , and e . It is in fact a complete roll (dotted in Fig. 17) in which all the expanding and a part of the reducing zones have been omitted. If such a roll is to be used to expand instead of to reduce, it is set in the same way and revolved in the opposite direction. However, it is so easy in my machine to set rolls in any desirable position that I prefer to change zones from reducing to expanding ones not by reversing rotation, but, as already explained above, by change in angularity. The change in angularity, as seen in Fig. 48, does not really change the amount of angularity, but only the direction and place in which it is measured.

In mounting rolls no attention is paid to the roll constants or factors which determine the size and proportions of the rolls, such as diameters, length, or taper. If two given rolls, however different in size and proportions, have equal offsets, angularities, and eccentricities, they are set in exactly the same way—that is, so their axes and the center of their base-circles shall occupy exactly the same place in space. The base-circle of a roll is the one from which the eccentricity e is measured, and this is the circle that bears against collar 85 of the roll-shaft.

In the following table I give a list of the factors of relations a , o , and e of the three sets of rolls shown in Figs. 16 to 21. The scale of inches will be found on the base A in Figs. 19 to 21, and with such scale the eccentricities may be measured in Figs. 16, 17, and 18, where I have omitted the eccentricity-scale.

	a .	o .	e .
Roll of figures 16 and 19	18 degrees.	2.4 inches.	9.6 inches.
Roll of figures 17 and 20	18 degrees.	1.4 inches.	11.5 inches.
Roll of figures 18 and 21	86 degrees.	1.4 inches.	2.3 inches.

It is seen that the rolls of Figs. 16 and 17 have the same angularity (eighteen degrees) and that those of Figs. 17 and 18 have the same offset (1.3 inches) and that although the rolls differ materially in shape and proportions such differences have no influence whatever on the adjustments. This appears most clearly in comparing Figs. 20 and 21, where the stocks B B' occupy exactly the same relation, although the roll in one case is much larger and has very much more taper than in the other.

The roll of Figs. 16 and 19 is what I have called the "complete" roll, the roll of Figs. 17 and 20 has the general proportions of what are known as "cones," and the rolls of Figs. 18 and 21 have the general proportions of what are known as "disks." Whatever called, if all non-twisting they all must be hyperboloid

zones—that is, each a zone of a certain unlimited complete non-twist reducing and expanding hyperboloid-roll.

The hyperboloid in which the disk of Figs. 18 and 21 is taken has the general proportions of the hyperboloid shown dotted in Fig. 18 and cannot be used as a complete roll, because the expanding zone of each roll would interfere with the reducing zone of the other roll. The reducing zones of non-twist rolls of all possible proportions have no such limitations and may extend indefinitely away from the common perpendicular as far as desired. This is also true of their expanding zones. In explaining the effects of changes in roll relations later on, it will be convenient to first consider the effects on reducing zones extending from the common perpendicular to a great distance therefrom.

If a complete reducing and expanding roll, such as that of Figs. 16 and 19, is defective, its action on the metal will consist in giving a certain amount of twist in the reducing part of the pass and a greater amount of opposite twist in the expanding part, and as a result the finished tube may show very little twist and still have been subjected to considerable twisting action. In fact, with the reduction equal to the expansion my rolls, even when defective, may be considered as non-twisting in the sense in which the term has been used by certain inventors—as, for instance, by Stiefel in his Patent No. 551,340 of December 10, 1895, where certain roll elements are relied upon to undo the mischief done by others, and thus yield what he calls a “mean effective” non-twist. My purpose is to avoid any conflicting action in all parts of the pass, so that all the roll elements shall operate harmoniously to the same end and shall all be non-twisting, and therefore in testing my rolls I first use them mainly to reduce or mainly to expand, so as to bring out the defect in full. If the result is not exactly what it should be, the defect may be cured by equally modifying the shape of the two rolls in the manner set forth in my Patent No. 651,790; but this is a difficult operation because of the danger of overcorrection and impossibility of restituting parts removed and is furthermore impractical because of the cost in time and expense necessary to secure the degree of precision required. All this can be avoided by changing the relation of the rolls instead of their shape. Any change in result got by change in shape can, I have discovered, be got just as effectively and far more easily by change in relation. The whole difficulty was to know what this relation is in the simplest possible terms and how it might be changed to secure any desired change in result. The relation I have shown is fully determined by offset, angularity, and eccentricity, and the changes in arrangement consist simply in changing any one or more of these factors. By this method overcorrection instead of being dreaded and avoided is rather sought to get the

quickest results in a process of successive overcorrections.

Any change in the offset, angularity, or eccentricity of a non-twist reducing-roll will be found to change the rotative effect of the different roll-circles, which throughout all adjustments are supposed to be revolved at a constant rate. A change that leaves the smallest billet-section revolving faster than the larger billet-sections I shall call “fore twisting,” a change that leaves such smallest billet-section revolving slower than the larger billet-sections will be “back twisting,” and finally a change that leaves the smallest billet-sections revolving as fast as the larger billet-sections, although slower or faster than before adjustment, is “non-twisting.” The effects on a true non-twist roll being known, they will be substantially the same on a roll that is only approximately non-twisting, except that a change which is fore twisting on the true roll will not necessarily produce fore twist on a defective roll, but may only reduce an excessive back twist or completely correct such back twist and produce no twist, or finally overcorrect and produce a slight fore twist. In like manner the change which is back twisting may only reduce an excessive fore twist and leave a roll fore twisting, or it may completely correct such back twist, or finally it may slightly overcorrect and produce a slight back twist. A change that is fore twisting made in a fore twist roll increases the fore twist, and similarly a change that is back twisting made in a back twist roll increases the back twist.

It may be well to note here that a same spiral arrangement of fibers of low twist may be produced by either fore-twist rolling or by back-twist rolling, because any twist is a fore twist if the billet while being rolled was revolved in one direction and a back twist if revolved in the opposite direction, and while the results are the same the manner in which they are produced is not.

The nature and extent of any change in twisting effect due to any given change in adjustment are best seen in the reducing zone of a perfect non-twist roll by comparing the rotative effects at the common perpendicular with those at a considerable distance from it.

In Figs. 24 and 25 I have represented the side and end views of a billet and its non-twist reducing-roll and shall show how differently any change in adjustment affects the smallest circles N and N' and the large circles M and M' . Such difference in effect being due to the notable difference between the relation of the larger circles and that of the smaller circles, I shall first explain these relations. The contacting elements of the small circles are in a vertical plane parallel to the axes F and K , while those of the large circles lie almost in a horizontal plane. The perpendicular through Z to the contacting elements of the small circles is a horizontal line CX , while the perpendicular through G to the contact-

ing elements of the large circles is a line 345, which is almost vertical. The perpendiculars CX and 345 meet the two axes K and F. It is by looking in the direction of these perpendiculars that the true angular relation of the contact elements is seen. Thus the elements at Z when so viewed appear as in Fig. 24, where the roll element is seen to act across the billet element at an angle equal to the angularity of the axes. All the roll-circles act thus obliquely to their billet-circles, but it is the smallest roll-circle that acts at the greatest degree of obliquity. As the circles become larger they cross less and less, Fig. 24, and act less and less obliquely until the large circles may be considered as being in about the same relation as plain bevel-gears whose axes intersect. The reason for this is that all the circle-axes being coincident have the same offset and that this offset becomes relatively smaller and less important as the circles increase in size. The difference in obliquity is very clearly shown in Fig. 27, reproduced from my Patent No. 651,790, before referred to and in which the driving-point of the smaller roll-circle N moves along t at a considerable angle across the direction t' of the contacting element of the billet-circle N', while the contacting elements of the large circles M and M' cross at a very small angle t & t' . In this figure the axes are for clearness supposed to be in horizontal planes instead of in vertical planes—that is, the roll of Fig. 25 must be supposed turned about the billet-axis counter-clockwise through a right angle. It is now clear that any change in offset, angularity, or eccentricity must have an effect on the small circles very different from its effect on the large circles.

Changes in offset.—What this difference in effect for increase in offset is is shown in Fig. 26, where an increase equal to $Z Z'$ almost doubles the small billet-circle and hardly affects the large billet-circle. The reason for this difference is that by increase in offset every point of the roll is moved horizontally away from the billet through a same distance and that at Z the motion is perpendicular to the contacting elements and acts in full to separate them, while at G this same motion is almost in line with the contacting elements and tends to make them rather slide than separate. As the angular relations are not changed, the changes in the billet radii are a measure of the changes in rotative effect and therefore the small billet-circle N'' must now revolve about half as fast as before, while the large billet-circle M'' revolves only a trifle slower, and as the combination of Fig. 25 is supposed to be non-twisting the small circle N'' of Fig. 26 must now drag and cause back twist. Increase in offset therefore produces back twist. The inverse proposition that decrease in offset produces fore twist naturally follows. Both conclusions could be easily established with the aid of diagrams similar to those of Figs. 22 and 23 by showing that for

axes in the relation of Fig. 26 a roll having a small circle equal to N to be non-twisting should have a large circle smaller than M. M therefore represents the increased large circle of a non-twist roll, and such increase causing the base of the billet to revolve faster must produce back twist.

It is already seen how the rolls of Fig. 16 may be easily corrected for excessive back twist by reduction of offset and for excessive fore twist by increase of offset and how the amount of correction necessary to produce non-twist rolling may permit of determining for use in building other rolls the coefficient of flattening which expresses the relation between my "practical roll" and my "theoretical roll." Any corrected roll is necessarily my "practical non-twist roll" for axes in the relation where they happen to be after correction, and my theoretical roll for the same relations of axes may be determined from the number of revolutions of roll and billet after correction.

Changes in angularity.—Correction may also be made by change in angularity, the effect of which is best seen, as in the case of change in offset, by comparing the effect at the small circles with that at the large circles in a reducing-roll that is supposed to be exactly non-twisting. (See Figs. 24 and 25.) At the small circles increase in angularity does not affect the size of the billet-circle; but it does increase the obliquity of action of the roll-circle and therefore reduces its rotative effect on the billet. At the large circles increase in angularity does not materially affect the obliquity of action; but it increases the billet-circle and acts to reduce the rotative effect of the large roll-circles. Increase in angularity therefore reduces the rotative effect at the small billet-circle and also at the large billet-circle, and whether the final result is back twist or fore twist will depend entirely on whether the percentage of loss at Z is greater or less than the percentage of loss at G. I have found that for any small displacement the loss at Z may be either less or greater than at G, according to the angularity of the roll, and that there is one angular position of the roll where a small increase in angularity causes equal losses at Z and G and therefore does not produce any change in the degree of twist. To make this clear, I must first explain how the percentage of loss at Z may be compared with that at G for any given angularity. In Fig. 28 the driving-point of the small roll-circle is supposed to have a velocity represented in amount and direction by arrow m , perpendicular to the elevation K of roll-axis. The velocity m resolves into a horizontal component f' , representing feed, and a vertical component n , representing the rotative effect. If the angularity of the roll is increased by an arc s , the velocity m is changed not in value but in direction to m' , where its rotative component, which is now smaller, is represented in value by n' at the

right. The component n' really coincides in direction with n on the vertical line K^{20} ; but to avoid confusion it is better to consider, instead of the components themselves, the equal lines n and n' at the right, bearing in mind that these lines represent value and not position. The horizontal line 333 through the end of m' determines on n the amount by which n has been shortened and the relation of this amount to the line n is the fractional loss in rotative effect. The same horizontal line 333 cuts off of m a length l which bears the same relation to m that the loss in n bears to n . If m , therefore, is supposed to represent one hundred units, l will represent the percentage of loss in rotative effect at the small circle. The percentage of loss at the large circle is found in about the same way, and in order that the two results may be compared I have selected point G , so GX , representing one hundred units, shall be exactly equal to m . When the angularity of the roll is increased by an amount s , the radius GP of the large billet-circle is increased by an amount GG' , which bears the same relation to GP that l' bears to GX . The length l' , which is found in the same manner as l , by drawing a horizontal line through one end of the small arcs s , represents the percentage of increase in the billet-circle, and if it be not very large also represents the percentage of loss in rotative effect. The exact loss is represented by the ratio of l' to $(GX+l')$ and for large values of l' is appreciably smaller than the ratio of l' to GX . For the roll shown in Fig. 28 the increase s in angularity produces a loss l in rotative effect at X of about eight per cent., and at G a loss l' of about twenty-four per cent. Therefore if the roll in the full-line position is non-twisting and if in a certain time it causes its billet to make one hundred revolutions the same roll in the dotted position will in the same time revolve its billet so it will make at X one hundred minus eight or ninety-two revolutions, and at G only one hundred minus twenty-four or seventy-six. Increase in angularity in this special case therefore produces fore twist, and it always does produce fore twist when the loss at G is greater than the loss at X , or whenever l' is greater than l , and this is the case so long as angle h and its equal h' remain larger than the billet-angle i . (The angle i cannot bear the same definite relation to the irregular billet that the roll-angle j bears to its perfect roll. In fact, being determined by the roll-angle j , it belongs more to the roll than to the billet; but the designation "billet-angle" is convenient, and with this explanation it is not thought that its use will be misleading.) When the billet-angle i equals angle h , and therefore also angle h' —that is, when the roll-angle j lies midway between the horizontal line F and the vertical line K^{20} , as in Fig. 29— l' equals l , and increase in angularity causes as much loss at X as at G , producing neither fore twist nor back twist, but only a slight reduc-

tion in the rotary speed of the billet. Beyond the position of Fig. 29—that is, when the roll-angle j is closer to K^{20} than to F , as in Fig. 30— l' is smaller than l and any small increase in angularity of the roll introduces back twist. It is not practical to thus increase angularity as in Figs. 29 and 30, because the pass is soon made to converge so rapidly that the rolls will slip on the billet and not draw it in; but the principles are true, nevertheless, as would be seen if the billet could be forced into the pass by external means. When the roll-angle j , Fig. 31, is so large that it may lie closer to K^{20} than to F without leaving too big a billet-angle i , the principles apply in full and the roll supposed to be non-twisting in position E^1 becomes fore twisting if its angularity is increased and will become more so until its roll-angle lies midway between F and K^{20} , as at E^2 in the dotted position which corresponds to the set of the roll in Fig. 29. Beyond this midway position E^2 any increase in angularity introduces back twist, and if the increase in angularity be carried far enough the roll will again become non-twisting. Thus the roll in positions E^1 and E^3 is equally non-twisting. There are therefore for a given offset and eccentricity two angular positions of a roll in which it is non-twisting. These positions are theoretically equidistant from the midway position; but as the roll in one case forms a pass converging more rapidly than in the other the coefficient of flattening is not the same and the two positions cannot in practice be exactly equidistant.

The effects of adjustment in angularity are seen to depend very much in practice on the proportions of the roll used. When the roll-angle j is small, as in the rolls of Figs. 28 and 29 first under consideration, the practical limit of the billet-angle i is reached before the midway position, Fig. 29, and in such case the rule within the limits of practice is that increase in angularity produces fore twist and inversely that decrease in angularity produces back twist. When the roll-angle j is large, the angular adjustments are about the midway position—that is, before, at, or beyond it—and the rule then is more easily stated by using the midway position as the base of reference. Departure either way from the midway position produces back twist and inversely approach produces fore twist. This is the general rule of twisting effect due to the adjustments in angularity and applies for all values of the roll-angle j . The fact that certain angular positions are impractical does not affect the rule. In applying this rule it is convenient to use an adjustable pointer 359, Fig. 18, which may be set to indicate the angularity of the roll when its roll-angle j lies in the midway position. Any change in angularity that decreases the distance between index 342 and this pointer 359 introduces fore twist and inversely any change that increases this distance introduces back twist. This rule answers for any possible roll provided

only that the adjustable pointer be set to correspond, as explained. Thus in Fig. 18 the pointer 359 should be set at eighty-four degrees and in Fig. 16 at fifty-two degrees.

5 A roll in the midway position has the highest degree of fore twist that it can have with a given offset and eccentricity, and if a roll be still back twisting in the midway position its back twist will here be less than at any other

10 angularity. If a roll in one of its non-twist positions be set angularly closer to the midway position to become slightly fore twisting it may be rendered again non-twisting by an increase in offset which shall introduce

15 an equal amount of back twist annulling the fore twist. Any increase in offset furnishes in this manner two new non-twist positions, which become closer and closer as the offset is increased until the two finally merge into

20 one, which lies in a midway position. After the merging position any further increase in offset gives the roll a back twist, which cannot be cured by angular adjustment, because any such adjustment must be away from the

25 midway position, adding back twist and making matters only worse. If a roll in the non-twist position, where its billet-angle and offset are very small, have its angularity gradually increased to ninety degrees as a limit

30 and it be desired to keep it non-twisting throughout such angular motion by proper change in offset, it will be found that the offset will have to be gradually increased until the midway position is reached and that beyond

35 such position it will have to be gradually decreased. To any given degree of angularity there will correspond one certain amount of offset and for any given value of offset within the limit will be found two corresponding

40 angularities.

The correspondence between the offset and the angularity of a roll which is moved through its different non-twist positions is dependent on a law which though not easily

45 put in words is not complicated and may be embodied in a very simple diagram. In Fig. 32 I show such a diagram for a roll whose roll-angle j of fifteen degrees is selected small for clearness. A roll having so small a roll-angle could not in practice (for the reason

50 given above in considering Figs. 30 and 31) be adjusted as widely as shown in the diagram. The different lines $K K^1 K^2 K^3 K^4$ represent the roll-axis at different angularities

55 with respect to the billet-axis XF and the perpendiculars $QP, Q^1 P^1, Q^2 P^2, Q^3 P^3, Q^4 P^4$, the corresponding offsets which are seen to increase with the angularity until Q^3 is reached, after which they decrease as the angle increases. The angle FXQ^3 is measured by one-half of the arc PQQ^3 and is equal to one-half of the roll-angle j plus one-half a right angle, which sum is the angularity of a roll in the midway position. (Seen in Figs. 16

65 and 18 by the position of pointer 539.) Positions that are equidistant from the midway position Q^3 or the position of maximum offset

have offsets that are equal. Thus positions K^2 and K^4 have equal offsets $Q^2 P^2$ and $Q^4 P^4$, which conforms with what I have given above.

70 To construct this diagram, the first step is to draw an angle KXF equal to the roll-angle j and representing, therefore, the smallest possible degree of angularity. Selecting a center on the upper side of this angle, describe

75 the circle passing through X and draw any desired number of different positions $K^1 K^2, \&c.$, of the roll-axis. The distance of the intersections $Q^1 Q^2, \&c.$, thus found from line F represent, as stated above, the corresponding

80 offsets. The theory of this diagram is explained with the aid of the diagram, Figs. 22 and 23, which, it must be remembered, determine the proportions of a non-twist roll for axes in a given relation. In the present

85 case it is the roll that is given instead of the relation of the axes. Thus in Fig. 22 the roll-angle KXG and in Fig. 23 the distance CZ , which are roll constants, are now known, and the unknown quantities are in Fig. 22 the

90 angularity a and in Fig. 23 the offset o . I have shown that there corresponds to any given degree of angularity one certain offset, in which a given roll is non-twisting. Thus in Fig. 33, selecting an angularity of twenty-

95 five degrees for a roll whose roll-angle is fifteen and whose smallest radius is CZ , we find that the offset should be for a theoretical roll CX , which bears the same relation to CZ that $Q^1 P^1$ bears to $Q^1 G^1$. In Fig. 34 the same roll at

100 an angularity of thirty-five degrees would, to be non-twisting, require a larger offset CX' , which bears the same relation to CZ that $Q' P'$ bears to $Q' G'$. Now there is no difficulty in comparing the offset CX and CX' , because

105 they are referred to a same unit CZ , and there would clearly be no difficulty in making the comparison directly in lines $Q^1 P^1$ and $Q' P'$ without plotting the offsets if the parts QG and $Q' G'$ could be kept equal. This can be

110 done by proper variation of the distance of QP from X , which variation does not effect the ratios. Thus in Fig. 34 by shifting $Q' P'$ to $Q^2 P^2$ the segment $Q^2 G^2$ included in the roll-angle is made equal to $Q^1 G^1$ of Fig. 33

115 and the line $Q^2 P^2$ may represent offset on the same scale as line $Q^1 P^1$ of Fig. 33. If this shifting be done for a whole series of similar diagrams, it will be found that when the diagrams are superposed, so as to have their X

120 points and the billet-axis F coincident, the points of intersection $Q Q^1 Q^2, \&c.$, will all lie on a circular arc, such as traced in Fig. 32. The off-sets thus found being those of my "theoretical roll" should all be reduced by a certain

125 amount to allow for flattening, and the effect of flattening may be indicated in the diagram by a dotted-line modification 361 of the circular arc. Such modification slightly changes the position of maximum offset, which change

130 should be allowed for in setting the pointer 359.

In all of the above discussion I have not mentioned the expanding zone or that part

of the roll which lies beyond the common perpendicular, because any change in offset or angularity which has a correcting effect on the reducing zone has an equal correcting effect on the expanding zone. The purpose of all the corrections so far considered is to make the smallest roll-circle have the same rotary effect on the billet as the larger roll-circles of the reducing zones, and when this is done for the reducing zone it is done to an equal extent for the symmetrically-placed circles of the expanding zone. On account of the difference between the action on the metal of expanding and reducing zones it is desirable to not preserve this exact symmetry of zones and pass, and the way to do this is to shift the rolls along their imaginary axes, so the center of their smallest circles shall be out of the common perpendicular. Such shift changes the eccentricity of the roll and constitutes an adjustment in eccentricity, which is the third and last adjustment to be treated; but before leaving the question of offset and angularity I must direct special attention to the fact that if a roll be used as an expanding-roll the rules for correcting given above are all reversed. A reversal of rules being confusing, it is easier to leave them as they are and to translate the defect into what it would be if the roll were used to reduce. Thus if the roll is either back twisting or fore twisting as an expanding-roll it will, conversely, be either fore twisting or back twisting as a reducing-roll and may be corrected for its "translated defect" by the rules as they stand.

When a complete roll is corrected or modified in any manner, the change equally affects all elementary zones of the roll, and hence any separate zone, as that in Figs. 8^a, 8^b, and 8^c, having its proportion of the twisting action that might be present in its corresponding complete roll is corrected for fore twist and for back twist by the proper adjustments in offset and in angularity in the same manner and not proportionally, but in exactly the same degree as would be required to correct the correspondingly-greater defect in the complete roll. Such zone may be adjusted in the same manner as its complete roll, by proper changes in offset and angularity, to roll without twist any desired size of billet.

Changes in eccentricity.—Having fully explained the effects of changes in offset and changes in angularity and of simultaneous changes in both, I shall now explain the effects of changes in eccentricity.

Let E' , Fig. 44, represent a non-twist reducing hyperboloid zone, which is selected at a distance from the common perpendicular where the roll and billet in the side view overlap very little and most nearly show their line of contact. An increase x in the eccentricity e of this roll adds an equal amount y to all the billet radii, as best seen in Fig. 45, where the billets are shifted to facilitate

comparison. This increase in the billet causes a general loss of rotative effect and, being the same for all sections, causes a proportionally-greater loss at the small or exit end. In the case illustrated the loss at the small end is about one-half and at the large end only about one-quarter—that is, if the different billet-sections originally made four revolutions in a given time the enlarged billet will in the same time make only two revolutions at the small end and three at the large end, and thus have put in it one complete back twist at every third turn of the unreduced part of the blank. Increase in eccentricity, therefore, produces back twist and, conversely, decrease in eccentricity produces fore twist. The exceptions to this rule are so far out of the practical forms and proportions that they need not be at all considered. The back twist of the roll in the dotted position, Fig. 44, can obviously be corrected by bringing it back to the original non-twist position (shown in full lines)—that is, by reducing eccentricity—but it may also be corrected either by reducing offset or by increasing angularity, and when thus corrected the zone is placed in one of a new series of non-twist positions, through which it may be carried by coordinate changes in offset and angularity. Excessive back twist, therefore, and consequently, also, excessive fore twist, may be corrected in any hyperboloid zone in any one of three different ways—that is, by changing offset, angularity, or eccentricity. As in the case of offset and angularity, the correction of an expanding zone by change in eccentricity requires a reversal of the rules, which is avoided by translating the defect into the corresponding reverse defect of a reducing zone; but adjustment in eccentricity cannot be applied to a complete reducing and expanding roll, because it does not act symmetrically with respect to the common perpendicular. Thus an increase in eccentricity which virtually decreases all the circles of the reducing zone on the contrary increases all circles of the expanding zone. (See Fig. 46.) It follows that in a complete expanding and reducing roll adjustment in eccentricity should not be used except to accurately set the rolls so the centers of the smallest circle shall lie in the common perpendicular, or else so as to slightly displace said center and create by virtue of the asymmetrical action of such adjustment a certain asymmetry in the pass to compensate for the differences that necessarily exist in the reducing and expanding operations.

When a roll has been tried and its coordinate adjustments have been determined for all non-twist positions, it will be found in many cases that a certain one of the three adjustments a , o , or e may be permanently fixed and only the other two left variable, and in certain rare cases even two of them may be permanently fixed—as, for instance, in the case of a disk-roll normally lying at the midway position, when both offset and eccentric-

ity might be kept invariable for a considerable range of different work.

Frustum-rolls.—Under the head "Use of the machine" I give above a brief exposition of the non-twist rolls of my Patent No. 651,790, and I explain, with the aid of Figs. 16 to 21, how such rolls are to be mounted. The zone-roll of Figs. 17 and 20 and the zone-rolls of Figs. 18 and 21 being each included between planes perpendicular to the axis of the complete roll in which they are taken, may very properly be called "frustum-rolls."

A frustum-roll, as explained under the head "Changes in angularity," may in the same manner as its complete roll by proper coördinate changes in offset and angularity be carried through a whole series of non-twist positions to roll billets of different sizes; but it has the further advantage that it may vary considerably in eccentricity and that for each set in eccentricity it may be carried through a new series of non-twist positions by a new series of changes in offset and angularity. This is fully explained under the head "Changes in eccentricity." Now according to my roll patent a non-twist roll, whether complete or only frustum, must apparently have an invariable eccentricity. Thus a complete roll must be set so its smallest circle shall lie in the horizontal axis of the turn-tables of my machine, and any frustum of such a roll must lie as it would if still a part of its complete roll. The obvious explanation of this apparent inconsistency between the present application and my patent is that when a non-twist frustum-roll is changed in eccentricity and offset to be again non-twisting it has become in its new set the approximate equal in shape, size, and position of a different zone in a different complete roll. Any given frustum-roll can therefore by proper changes in set act for and be used in the place of an infinite number of approximately-equal non-twist frustums, and, as most of the frustums of any given series differ very little from a pure cone-frustum, there is no practical reason for attempting to give any frustum-roll an exact hyperboloid profile. My frustum-rolls therefore may be considered as pure and simple cone-frustums, which may vary considerably in shape and proportions from the so-called "cones" of Fig. 17 to the so-called "disks" of Fig. 18. "Cones" and "disks" are not different kinds of rolls, as might be supposed from the difference in terms. In my machine they are both simply frustum-rolls having the same roll-constants and the same factors of relation and differing only in the degree of some or all of their data.

The setting of a cone-frustum for non-twist is a process of identification of the cone-frustum with a particular hyperboloid zone. A complete hyperboloid may be considered as an aggregate of cone-frustums of gradually-varying taper. (See elevation, Fig. 42, and end view, Fig. 43.) The middle zone has

no taper and may be considered as a cylinder. All other zones have taper t , which goes increasing with the distance from the center C'' through all intermediate values up to the roll angle or inclination j of the generatrix as a limit. The generatrix of the hyperboloid necessarily passes through the end circles of any given zone and likewise also through the end circles of the equivalent cone-frustums. A given cone-frustum may be identified with a hyperboloid zone by first selecting a generatrix or line passing through its end circles. To illustrate this point, I show in Figs. 43^a and 43^b a quarter of a cone-frustum E^3 , set to fit in the angle formed by a horizontal plane 370 and a vertical plane 371, so its axis coincides with the intersection of the planes, which are added to give a better idea of relations. A generatrix set at G' to meet the cone-axis at 372 will simply generate a pure cone or hyperboloid having a gorge-radius equal to zero. This generatrix-offset from the vertical plane through a distance r^2 and again set to pass through the end circles of the cone will lie at G^2 and will meet the horizontal plane at 373 to generate a hyperboloid surface H^2 , Fig. 43^a, passing through the end circles of the cone-frustum and having a gorge-radius r^2 . A generatrix having an offset r^3 will generate an entirely different hyperboloid H^3 , still passing through the end circles of the cone-frustum, but having a gorge-radius r^3 , Fig. 43^b. In Fig. 43^b it is clearly seen that the roll-angle j and the gorge-radius r are variable and depend for their value on the value of the eccentricity, both increasing as eccentricity decreases. No straight line, as G^2 or G^3 offset from the axis, can be set to pass through the end circles of a cone-frustum, as shown in Fig. 43^b, without passing into the cone between the end circles, and when an attempt is made to set a straight edge in the position of line G^3 , for instance, the rule will be found to touch the conical surface only at one point between its end circles and to not quite reach either of these circles. The gaps left between such straight edge and the cone-frustum show substantially the departure of the cone-frustum from the true frustum-roll and will be seen to go decreasing as the offset r^3 of the rule is decreased—that is, as eccentricity is increased.

To show the extent and nature of the departures made by substituting cone-frustums for exact hyperboloid-rolls, I have made the diagram Figs. 35 to 40^a. In Figs. 35 to 38 a so-called "cone" E' is shown end on, with a generatrix Gg at different offsets r' r^2 r^3 r^4 , and in Figs. 35^a to 38^a the same cone is shown in side view with the four different hyperboloids generated by the line Gg in the four different relations of Figs. 35 and 36. The departure of the cone-frustum does not appear perceptibly until Fig. 37^a is reached, and does not become so large as to be probably objectionable until the offset of the generatrix is made equal to the radius of the smallest cone-cir-

cle, as shown in Figs. 38 and 38^a. In Figs. 39 to 40^a similar diagrams are shown for a so-called "disk" or flatter cone-frustum. If Figs. 35^a to 37^a be superposed in one, Fig. 41, so the centers of the different hyperboloids shall all coincide, it is seen how both the roll-angle j and the gorge-radius r decrease with increase in eccentricity. If the center C^{11} of this figure is supposed to coincide with the common perpendicular in the machine, the increase in e , causing both j and r to decrease, operates to virtually modify the shape of the hyperboloid-roll in which the equivalent zone is taken, and thus the adjustment in eccentricity, which is purely a modifier of roll relations, acts not only in effect, but substantially in fact, as a modifier of roll proportions. This result has the greatest practical importance, because it permits of changing the taper of a billet without changing its size or the non-twisting property of the roll. That a difference in twisting effect can be secured without changing the dimensions of either the roll or the billet can be shown with the aid of a dummy billet. If a given set of cone-frustums and a dummy billet be set in contact, so their axes are in a same plane—that is, if the rolls be fitted to the billet at zero, offset by proper changes in eccentricity and angularity—it will be seen that all roll-circles act in line with the contact elements of the billet-circles. Now if the rolls be offset and the billet again fitted as before (a very rapid operation in my machine) the different roll-circles, as clearly shown in Fig. 27, before described, must act obliquely to the different billet-circles and all lose in rotative effect; but the smallest circle, acting at the greater obliquity, loses the most, so that if the roll were non-twisting at zero offset it must now be back twisting. If the given rolls are non-twisting on the given billet at a certain offset, the same rolls will be fore twisting on the same billet at a smaller offset and back twisting at a greater offset, and this being known a given pair of rolls intended to roll a certain billet may with the aid of a dummy be corrected in set to roll without twist or to roll with either back or fore twist.

Within limits the exact taper of the billet is secondary, and all that is important is the smallest diameter of the billet, which may easily be preserved by a judicious combination of the three adjustments, the effects of which on so-called "cones" may be summarized as follows:

First, as to twisting effect: To correct back twist, add fore twist by reducing o or reducing e or increasing a . To correct fore twist, add back twist by increasing o or increasing e or decreasing a .

Secondly, as to dimensions: Increase in any one of the three increases the billet, and decrease decreases it.

For a given increase or decrease in size of billet the change in twisting effect is in the order $o e a$ —that is, greatest in offset and

least in angularity. Hence when the desired change is mostly in twist use offset or even eccentricity, which in special cases is nearly as effective, and when the desired change is in size use angularity, completing correction in either case with the other factors.

To preserve the exact smaller dimensions of the billet without the aid of a dummy, the operator may proceed by addition or by subtraction. Thus by addition he may correct partly with e or with o and finish with a , because to make a same correction in twist a and e or a and o make opposite changes in size. Thus to correct back twist reduce e , which reduces the billet, and increase a to increase the billet and restore its size. Both changes add fore twist and act additively to correct the defective back twist. To proceed differentially in the same case, reduce o , which reduces the billet, and increase e to restore its size. The reduction in o produces great fore twist, while the increase in e produces less back twist, leaving a certain amount of corrective fore twist. The three adjustments may be used at a time, and of course must be so used in connection with the dummy billet.

In applying correction it may be necessary to consider feed. For zones distant from the common perpendicular the rate of feed is most effected by offset, and for zones near the common perpendicular feed is mostly effected by angularity. Both angularity and offset are essential to secure feed, as there can be absolutely no feed if either one be made equal to zero, a principle which is necessarily involved in all self-feeding rolls, but which could not be clearly enunciated and thoroughly understood without the aid of my system, which contemplates a machine having embodied in its very structure the variable coordinates of roll relations.

The question whether a certain low-twist tube was rolled by fore or by back twist rolling is not indifferent, because while the product, however produced, may appear to be the same its physical qualities will depend very much on whether the rolling was fore twisting or back twisting.

When rolls are set to be nearly or entirely non-twisting, a slight change in adjustment causes great changes in the rolling action, because the rolling is very close to the critical point where a slight difference entirely changes the nature of the product, whereas a same or even larger change in rolls set to give a high fore twist would not appreciably affect the rolling operation.

Mannesmann, whose rolling produces a high fore twist, has at the smallest section of the reducing-pass a considerable feed and draw, which, he explains, contribute greatly to the opening up of his metal. In low-twist rolling and in non-twist rolling, and especially in back-twist rolling, the feed at the smaller section of the billet is much inferior, and the metal at this point is really upset. Hence in such rolling there can be no tearing apart or

opening up of the metal such as described by Mannesmann, and the metal cannot be opened up except in the widening part of the pass. The main object of the reducing action in low-twist rolling, as I have discovered, is to give the rolls the necessary hold or grip on the metal and by flattening to spread and enlarge its outer skin, so as to facilitate the opening operation. Success in low-twist rolling therefore depends greatly on the amount of flattening of the billet, and as the value of such flattening is dependent on a great many different factors and changes with any change in conditions a machine such as mine that contains in itself independently of the rolls a means of "correcting" the rolling action of any given pair of rolls is an absolute necessity.

When reducing cone-frustums have been set to roll the hot metal without twist, they will in accordance with my Patent No. 651,790 be found to be fore twisting on the body of revolution that fits between them that is on the perfectly-circular or dummy billet. This effect, which is due to the departures in shape of the real billet from the dummy, can be shown on a skeleton dummy, Fig. 50, made of two sections 380 and 381, mounted to revolve on a rod 382, representing the billet-axis. By the variation in the relative position of marks 383 the smaller billet-circle will be seen to be gaining on the larger, which action indicates fore twist. The slight compression of the dummy in the limited motion of the experiment does not appreciably alter the rotative effect.

In the special case where the rolls have no offset the rolls to have no twisting effect on the dummy billet should have their cone-apices coincident with the cone-apex of the dummy at the common perpendicular or point of intersection C'' of the axes; but the same rolls to have no twisting effect on the hot metal, which in this case should be fed by pressure 385, must be fore twisting on the dummy and must be set as diagrammatically shown in Fig. 51, so that their cone-apices shall be beyond the common perpendicular C'' , while the apex 386 of the dummy cone does not even reach it. With the aid of such a dummy the operator may see in an instant whether given rolls can at all be used to roll a certain billet with a certain desired degree and kind of twist or with no twist. Such a dummy is also most useful to set rolls that are suitable in a relation where they shall require very little, if any, final correction. In order that rolls may be so used with a dummy, it is absolutely necessary that they shall have universal adjustment or my equivalent limited adjustment, because rolls cannot be carried through their different billet-fitting positions without changing each and all of the three roll coördinates a , o , and e . Thus if rolls fitting a dummy are increased in offset o it will be found that they cannot again be fitted by simply reducing angularity a or by

simply reducing eccentricity e . A change in any one of the three necessitates certain corresponding changes in the other two, and hence any adjustment, however complicated, that is not the equivalent of mine cannot generally be used to fit a dummy in more than one position and not surely in that.

In a roll adjustment that is not universal there may be one set that will hold given rolls in one of their non-twist relations; but there cannot generally be more than one set, and this can only be found by chance or accident unless my system of measuring roll relations and the instructions given above be used and followed. While my system of roll measurements is a great aid in all cases, it cannot be used with full effect in any but a universal adjustment or its equivalent, such as mine, and then not conveniently unless the structural elements of adjustment correspond to the coördinates of roll relation. It is practically impossible without the aid of my three non-interfering adjustments to lay down any specific instructions such as mine by which the operator is led step by step in the right direction surely and quickly to the result sought.

From the above full and detailed exposition it is seen that twisting effect is so dependent on roll relations that no rolls can be said to be equal rolling unless their exact relation in offset, angularity, and eccentricity is either directly or indirectly given.

If the relation of a given pair of equal rolls forming a symmetrical combination is made certain in any way, such relation, however secured, may be stated in terms of offset, angularity, and eccentricity, and therefore I wish it clearly understood that I do not limit my invention to the exact means of adjustment herein described—that is, to one angular and two rectilinear adjustments—for I have found that a combination of one rectilinear and two angular adjustments will answer; but it has, in common with many other forms, the great disadvantage that any change in any one of its adjustments disturbs all the three factors of relation and necessitates a mathematical calculation to give an idea of the relations and permit the operator to know just what has happened. An adjustment may be highly complex and still lack the essentials of universality. Thus it is absolutely impossible to set rolls in any desired relation by three angular adjustments, although such adjustments would place rolls in very peculiar positions.

No amount of mere change in shape will yield the infinite variety of results to be got by changes in roll relations, and as my former application lays great stress on shape I have in the present application laid even greater stress on roll relations. In my machine a roll departing from a hyperboloidal roll as much as the roll shown in Fig. 8^d may be set to roll substantially without twist and, *a fortiori*, so may a roll which departs less from the hyperboloidal roll; but any such departure of

course introduces equal amounts of back and fore twist.

My contributions to the art are mainly a simple, clear, and scientifically-accurate system of measurements to determine roll relations, a disclosure of the manner in which a roll may be universally adjusted, the discovery that a simple combination of three adjustments in the case where the rolls are equal and to be similarly arranged about the billet is the equivalent of universal adjustment, the discovery of the changes in twist due to any certain change in relation, the discovery that a cone-frustum may be non-twisting, that it may be non-twisting in many different positions, and that it may be set to roll within certain limits of size, taper, and twist any given size and shape of billet with any degree of fore or back twist, and as a special and very important case with absolutely no twist.

In view of the unavoidable length of this specification it is thought desirable to here state that the part of my specification which most concerns the practical man will be found under the head of "Frustum-rolls."

Having fully described my invention, what I claim is—

1. In a seamless-tube or tubular-blank rolling machine having equal rolls to be similarly arranged with relation to the work, roll-adjusting means comprising three independent non-interfering adjustments of which one is angular and one is rectilinear.

2. In a seamless-tube or tubular-blank rolling machine having equal rolls to be similarly arranged with relation to the work, roll-adjusting means comprising three independent non-interfering adjustments of which one is angular and two are rectilinear.

3. In a seamless-tube or tubular-blank rolling machine having equal rolls to be similarly arranged with relation to the work, roll-adjusting means comprising three independent non-interfering adjustments of which two are rectilinear and at right angles and the third is angular in a plane perpendicular to one of the other two.

4. In a seamless-tube or tubular-blank rolling machine having a pair of equal rolls to be similarly arranged with relation to the work, roll-adjusting means comprising three adjustments of which one is rectilinear along the common perpendicular of the roll-axes, the other is rectilinear along the roll-axis and the last is angular on the said common perpendicular as an axis.

5. In a seamless-tube or tubular-blank rolling machine having a pair of equal rolls to be similarly arranged with relation to the work, carriages for said rolls, roll-carriage-adjusting means comprising three adjustments of which one is rectilinear along the common perpendicular of the roll-axes, the other is rectilinear along the roll-axis and the last is angular on the said common perpendicular as an axis.

6. In a seamless-tube or tubular-blank roll-

ing machine a pair of rolls and adjustments for varying their offset, angularity and eccentricity.

7. In a seamless-tube or tubular-blank rolling machine a pair of rolls adjustable in angularity and eccentricity, and suitable gearing arranged to keep the rolls constantly in connection with a fixed source of power through all adjustments.

8. In a seamless-tube or tubular-blank rolling machine, a pair of rolls adjustable in offset, angularity and eccentricity, and suitable gearing arranged to keep the rolls constantly in connection with a fixed source of power through all adjustments.

9. In a seamless-tube or tubular-blank rolling machine, a pair of rolls adjustable in angularity and eccentricity, and suitable gearing for equally and simultaneously varying at will, in both rolls, either one of the two coordinates without changing the other.

10. In a seamless-tube or tubular-blank rolling machine, a pair of rolls adjustable in offset, angularity and eccentricity, and suitable gearing for equally and simultaneously varying at will, in both rolls, either one of the three coordinates without changing the other two.

11. In a seamless-tube or tubular-blank rolling machine, cooperating skew-rolls mounted to be adjustable longitudinally of their axes, and means for so adjusting them, the means of the different rolls being connected by gearing to act equally.

12. In a seamless-tube or tubular-blank rolling machine, a pair of rolls adjustable in angularity and offset, and suitable gearing for equally and simultaneously varying at will, in both rolls, either one of the two coordinates without changing the other.

13. In a seamless-tube or tubular-blank rolling machine, a pair of rolls adjustable in offset and eccentricity, and suitable gearing for equally and simultaneously varying at will, in both rolls, either one of the two coordinates without changing the other.

14. Turn-tables mounted for angular adjustment, gearing for so adjusting them according to a certain law, shafts lying in the axes of said tables and geared to be revoluble according to the same law, parts mounted on said table for adjustment with respect to the tables, and adjusted by suitable connections with the said shafts.

15. Turn-tables mounted for adjustment according to a certain law, shafts lying in the axes of said tables and geared to be revoluble according to the same law, parts mounted on said table for equal radial adjustment with respect to the tables and so adjusted by suitable connection with the said shafts.

16. Turn-tables mounted for equi-angular adjustment in opposite directions, shafts lying in the axes of said tables and geared to be likewise equally revoluble in opposite directions, parts mounted on said tables for equal radial adjustment thereon and so ad-

justed through suitable connection with the said shafts.

17. In a machine for rolling solid or hollow ingots, billets or blanks to form tubes or tubular blanks, in combination with the mandrel thereof, cooperating rolls of the class described arranged to have their axes cross without meeting, and suitable supports for said rolls, all constructed and arranged to form structural coördinates in three dimensions on which the factors of roll relation may be directly measured, and the twisting effect of said rolls approximately determined, substantially as described.

18. In a machine for rolling solid or hollow ingots, billets or blanks to form tubes or tubular blanks, in combination with the mandrel thereof, cooperating rolls of the class described arranged to have their axes cross without meeting, and suitable supports for said rolls, all constructed and arranged to form structural coördinates in three dimensions on which the factors of roll relation may be directly measured, one of said coördinates being such as to lie in and coincide with the structural axis of the machine.

19. In a machine for rolling solid or hollow ingots, billets or blanks to form tubes or tubular blanks, cooperating rolls of the class described set to form a taper pass and having two coördinate adjustments contrived and arranged to change the twisting effect of the rolls independently and differently when changed to vary the dimensions of the pass, whereby the twisting effect of the rolls or the dimensions of the pass may be changed either separately or together, substantially as described.

20. In a machine for rolling solid or hollow ingots, billets or blanks to form tubes or tubular blanks, cooperating rolls of the class described set to form a pass tapering in the same direction as the rolls and having two coördinate adjustments contrived and arranged to change the twisting effect of the rolls independently and differently when changed to vary the dimensions of the pass, whereby the twisting effect of the rolls or the dimensions of the pass may be changed either separately or together, substantially as described.

21. In a machine for rolling solid or hollow ingots, billets or blanks to form tubes or tubular blanks, cooperating rolls of the class described set to form a taper pass and having two coördinate adjustments for changing the set of the rolls without changing the direction of the common perpendicular of their axes, such adjustments contrived and arranged to change the twisting effect of the rolls independently and differently when changed to vary the dimensions of the pass, whereby the twisting effect of the rolls or the dimensions of the pass may be changed either separately or together, substantially as described.

22. In a machine for rolling solid or hollow ingots, billets or blanks to form tubes or tu-

bular blanks, cooperating rolls of the class described set to form a taper pass and having two coördinate adjustments for changing the set of the rolls without changing the direction or location of the common perpendicular of their axes, such adjustments contrived and arranged to change the twisting effect of the rolls independently and differently when changed to vary the dimensions of the pass, whereby the twisting effect of the rolls or the dimensions of the pass may be changed either separately or together, substantially as described.

23. In a machine for rolling solid or hollow ingots, billets or blanks to form tubes or tubular blanks, cooperating rolls of the class described set to form a taper pass and having two coördinate adjustments for changing offset and eccentricity to vary the relative position of such rolls without changing the direction of the common perpendicular of the roll-axes, both of said adjustments being changeable independently whereby they may be used differentially to change the twisting effect of the rolls or the dimensions of the pass.

24. In a machine for rolling solid or hollow ingots, billets or blanks to form tubes or tubular blanks, cooperating rolls of the class described set to form a pass tapering in the same direction as the rolls and having two coördinate adjustments for changing offset and angularity to vary the relative position of such rolls without changing the direction of the common perpendicular of the roll-axes, both of said adjustments being changeable independently whereby they may be used differentially to change the twisting effect of the rolls or the dimensions of the pass.

25. In a machine for rolling solid or hollow ingots, billets or blanks to form tubes or tubular blanks, cooperating rolls of the class described set to form a taper pass, means for giving such rolls any operative relative position without changing the direction of the common perpendicular of the roll-axes and without disturbing the symmetrical disposition of the rolls about the pass-axis, and having two coördinate adjustments for changing offset and eccentricity to vary the relative position of such rolls without changing the direction of the common perpendicular of the roll-axes, both of said adjustments being changeable independently whereby they may be used differentially to change the twisting effect of the rolls or the dimensions of the pass.

26. In a machine for rolling solid or hollow ingots, billets or blanks to form tubes or tubular blanks, cooperating rolls of the class described set to form a taper pass, means for giving such rolls any operative relative position without changing the direction or location of the common perpendicular of the roll-axes and without disturbing the symmetrical disposition of the rolls about the pass-axis, and having two coördinate adjustments for changing offset and eccentricity to vary the relative position of such rolls without chang-

ing the direction of the common perpendicular of the roll-axes, both of said adjustments being changeable independently whereby they may be used differentially to change the twisting effect of the rolls or the dimensions of the pass.

27. In a machine for rolling solid or hollow ingots, billets or blanks to form tubes or tubular blanks, in combination with the mandrel thereof, cooperating rolls of the class described, adjusting means for placing such rolls in any conceivable relation symmetrical with respect to the pass-axis without changing the location or direction of the common perpendicular.

28. In a machine of the class described, and in combination with rolls adjustable in offset, angularity and eccentricity, means for varying the twisting effect of the rolls without varying the dimensions of the pass.

29. In a machine for rolling solid or hollow ingots or blanks to form tubes or tubular blanks, frustum-rolls, and roll-adjusting means for setting such frustums so they shall lie in the relative non-twist position of any one pair of the equivalent, different but approximately equal, non-twist, hyperboloidal zones.

30. In a machine for rolling solid or hollow ingots or blanks to form tubes or tubular

blanks, equal rolls having substantially the shape of conoidal frustums, and adjusting means for setting such rolls so their rotative effect on a dummy circular billet that fits between them shall be greater for the smaller roll-circles than for the larger ones.

31. Equal rolls having the shape of conical or conoidal frustums with a swell near their smaller end and set so the twisting effects due to the swell shall be equal and opposite to make the rolls as a whole non-twisting.

32. Equal rolls having the shape of a cone-frustum terminated at its smaller end by another cone-frustum of greater taper in the same direction, such rolls being set so the larger frustum shall be fore twisting and the smaller one back twisting to an equal extent.

33. In a machine for rolling solid or hollow ingots or blanks to form tubes or tubular blanks, equal rolls having substantially the shape of a cone-frustum terminated at its smaller end by another cone-frustum of greater taper in the same direction, and roll-adjusting means for setting such rolls so the larger frustum shall be fore twisting and the smaller one back twisting to an equal extent.

JOSEPH BECKER.

Witnesses:

R. W. BEALL,
J. FORD TAYLOR.